

2ND EDITION APR 2023

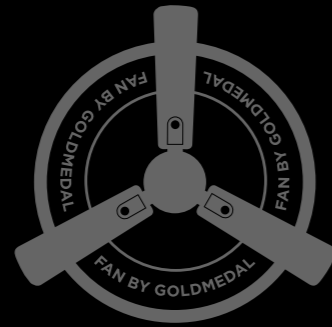

CUSTOMER CARE NO.
9711 09 09 09

**2k
23**
CATALOGUE

FAN CATALOGUE APR/2K23

Goldmedal[®]
SWITCH TO THE AMAZING



Let the wind
**Show your
Attitude.**
FAN BY GOLDMEDAL



 **Goldmedal**[®]
SWITCH TO THE AMAZING

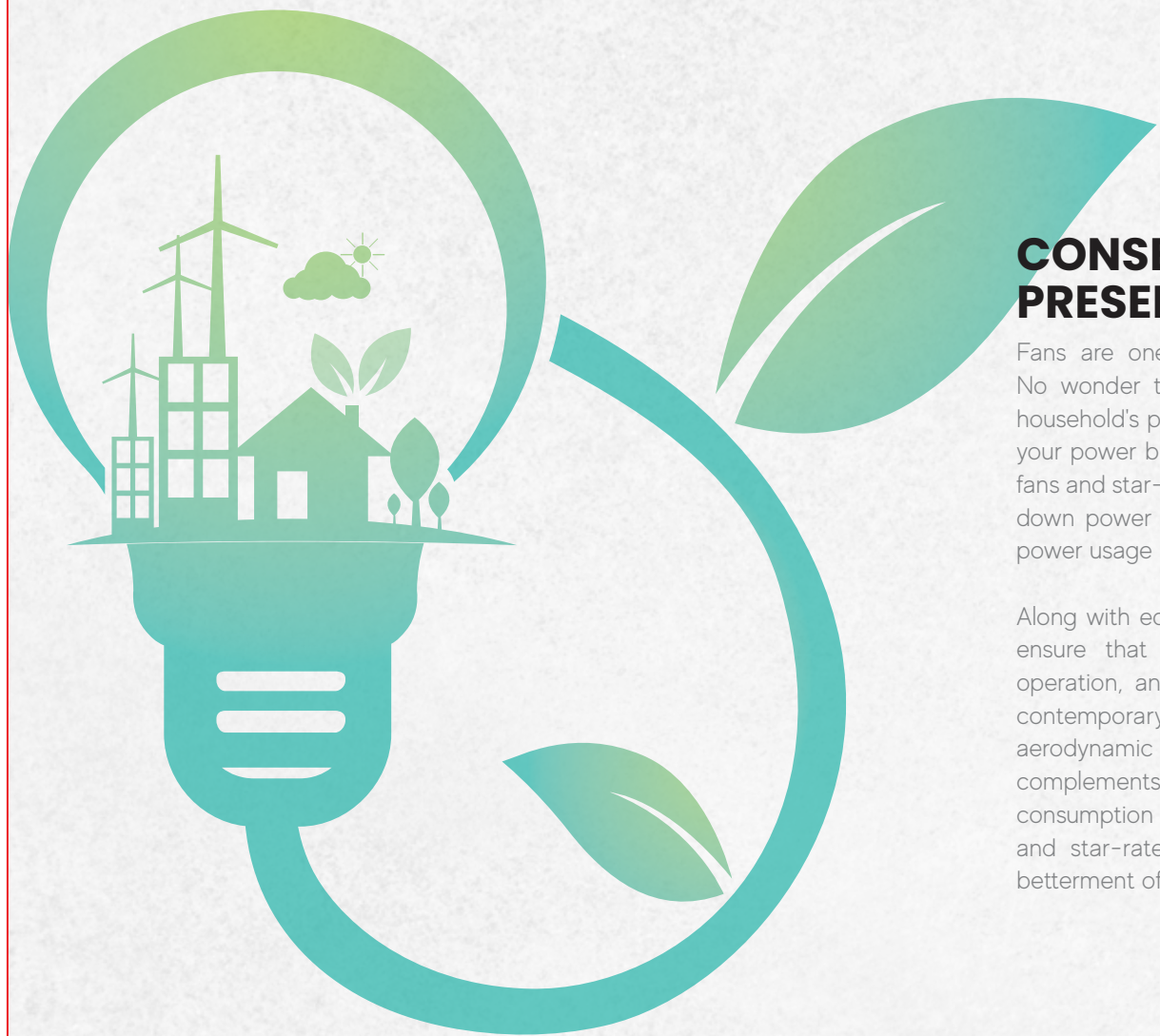

**CONSERVE ENERGY,
PRESERVE THE PLANET!**

Fans are one of the most heavily used electrical devices in India. No wonder they are responsible for a substantial part of a typical household's power consumption. At Goldmedal, we aim to help reduce your power bills and contribute to a greener planet through our BLDC fans and star-rated fans. These fans are a marvel of innovation - cutting down power consumption by up to 60%. and also ensure much less power usage compared to traditional fans.

Along with equipping our fans with power-saving capabilities, we also ensure that Goldmedal fans offer high-speed cooling, noiseless operation, and high aesthetic value. Created to meet the needs of contemporary living, Goldmedal fans are designed with advanced aerodynamic features, smart controls, and unique styling that complements the décor of every house. Minimizing energy consumption is the need of the hour and the Goldmedal range of BLDC and star-rated fans promotes an eco-friendly environment for the betterment of all life on earth.

**DID YOU KNOW THAT USING
GOLDMEDAL STAR RATED FAN FOR 10 YEARS
CAN...**

Reduce Electricity Consumption By 2686 Kwh
1 kg of coal creates 7.21 Kwh of electricity

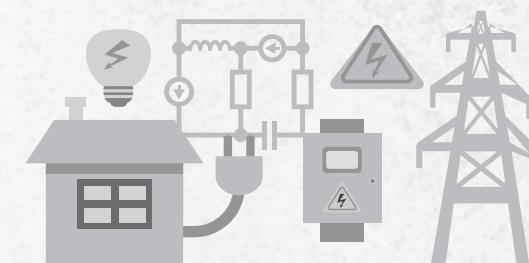

Reduce coal consumption by 372 Kgs
1 kg of coal creates 7.21 Kwh of electricity

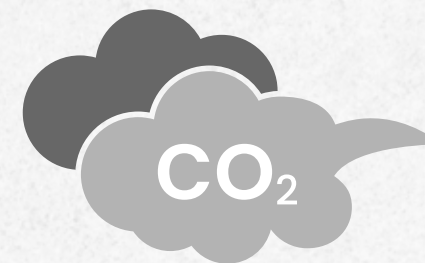

Stop 901 Kg of CO2 emissions
Burning a single kg of coal contributes to 2.42 Kg of CO2

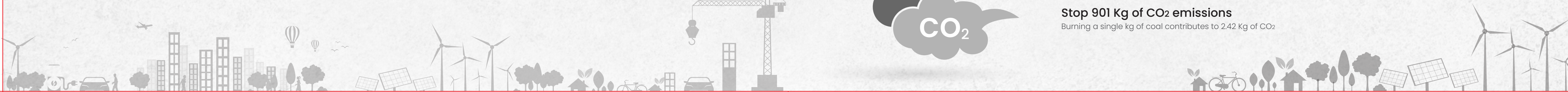



TURN ON THE
Breeze



Introducing, True Masterpieces.
The story of perfection in motion.

Considering India's hot and humid climate for the majority of the year, fans are a necessity in most Indian homes. With summer temperatures soaring with every passing year, there's now more reasons to have a fan in every room. Whether it's ceiling fans, wall fans, pedestal fans or ventilator fans, without one of these cooling appliances, you will find it difficult to stay cool and refreshed nowadays. But there's more to bringing home a fan than you thought.

Cooling technology and design has evolved so rapidly that you now have a plethora of choices when selecting a fan. From the right type to the right designs to energy efficiency, noiseless operations, lighting options, smart features, and many more - you can choose fans that meet your exact requirements. As a pioneer in manufacturing high quality wiring devices for more than four decades, Goldmedal incorporates the best in fan manufacturing technology to bring you fans that match your needs, perfectly.

Like our other appliances, Goldmedal fans are also designed and manufactured in India, keeping local climate conditions and needs in mind. We offer fans in every possible combination. Each fan is manufactured to the highest precision so that you experience superior cooling in the most energy-efficient way possible. Goldmedal fans are also designed to add aesthetic value to your room. Whether it's classical, contemporary, decorative, or smart - our fans will not only make your rooms feel cool but also look cool.

Contents

01 CEILING FANS

10-21 **SUPER DECORATIVE**
Daisy BLDC, Phantom BLDC, Viola, Hush-Air BLDC, Gladiator, Thor

22-39 **DECORATIVE**
Flora, Hero Prime, Insignia, Hoopla, Senora, Eva Prime, Enzo

40-55 **CLASSIC / CLASSIC DECO**
Air Crest, Airavat DX, Airavat, Vector, Gati Deco, Legacy 390, Geo Fox BLDC, Lux Flow BLDC,

56-63 **STANDARD**
Gati 400, Vegah 400, Air GT, Volt 400



02 LIFESTYLE FANS

66-69 Tricool, Adora

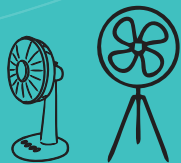

03 TABLE / WALL & PEDESTAL FANS

70-73 **TABLE**
Nora, Erica

90-109 **PEDESTAL**
Gloria, Nora, Erica, Olivia, Olivia Pro, Dyno, Dyno Pro, Falcon, G-Express, Torpedo, Turbo Storm

74-89 **WALL**
Nora, Erica, Olivia, Olivia Pro, Gloria, Dyno, Dyno Pro, G-Express

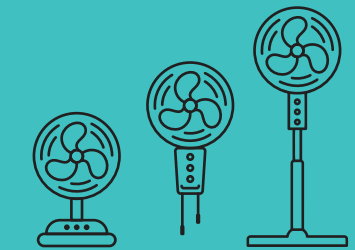

04 CABIN & PORTABLE FANS

110-111 **CABIN**
Astor

112-113 **PERSONAL FAN**
Tristar



05 AXIAL & VENTILATION FANS

114-127 **AXIAL**
Frost, Frost Prime, Air Vent, Nova Pro, Nova, Aero, Aria, Vento

128-137 **VENTILATION**
Air-Maxx, Air-Maxx HS, Air-Maxx Plus, Havoc, Havoc Plus, Rapido,



TECHNOLOGICAL REVOLUTION

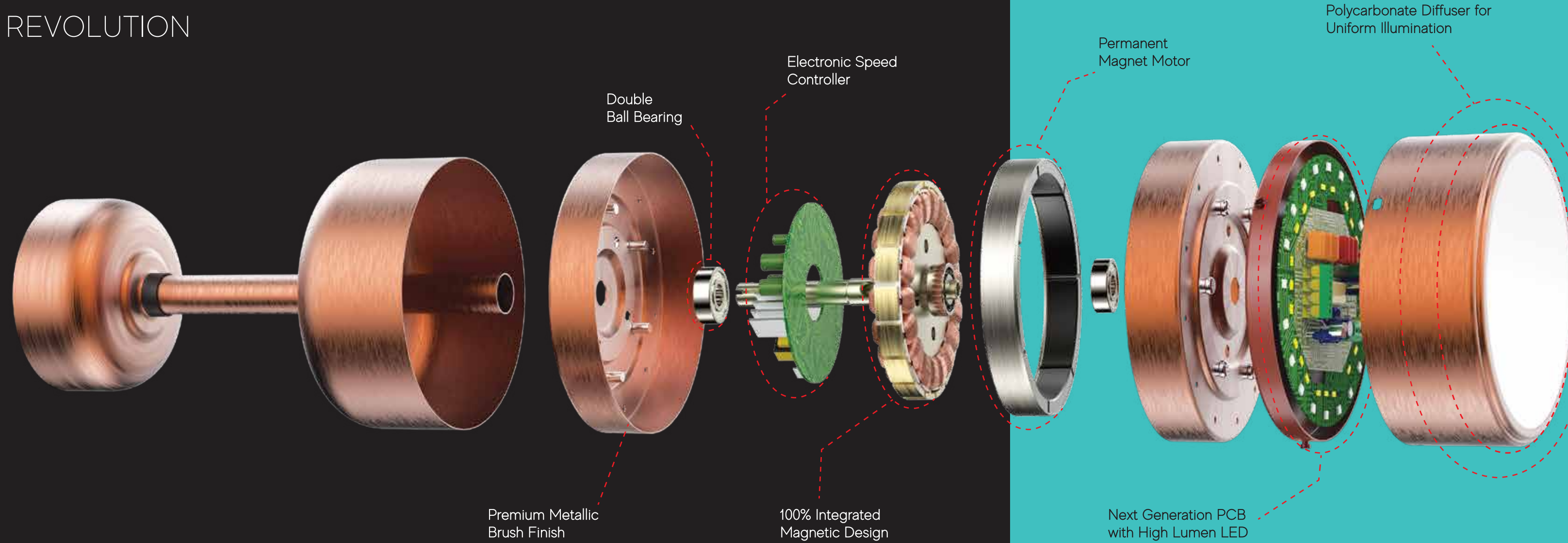

TECHNOLOGY FOR A CHANGING WORLD

For more than forty years, Goldmedal has been introducing some of the best ideas in electrical wiring devices. From mini modular systems to modular systems to home automation systems, LEDs, wires and cables, and more, Goldmedal products have become synonymous with high quality, innovative products.

Along with pioneering many innovations within the industry, Goldmedal has also grown into a leadership position with its pan-India reach and sheer volume of sales. As a brand, Goldmedal is now foraying into newer categories, starting with its exciting range of cooling ideas that include ceiling, wall, pedestal, table, and exhaust fans.

As an appliance that contributes significantly to a household's electricity consumption, fans can be an expensive necessity. Goldmedal is at the forefront of using the latest technologies to ensure that fans leave as low carbon footprint as possible. All Goldmedal induction motor fans are star rated which helps reduce overall power consumption while its BLDC fans can bring down power consumption by as much as 60%.

Goldmedal's portfolio includes BLDC as well as star-rated power-saving fans in standard, decorative, and smart categories that satisfy a wide variety of needs and aesthetic preferences. Attention is paid to the minutest detail to ensure that every fan delivers in terms of function and style. The company's extensive, nation-wide presence ensures seamless delivery and service while its network of branches in every state ensures ready support to all its channel partners.

Designed for modern lifestyles, the new Goldmedal range of fans are masterpieces in the truest sense. Designed, developed, and manufactured entirely in India, the fans by Goldmedal are a continuation of the company's Made in India endeavour.

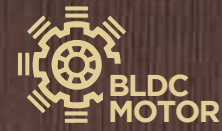

DAISY

Super Decorative Ceiling Fan

PRODUCT HIGHLIGHTS

- Magnificent Carvings For A Royal Decor • 100% High Quality Copper Motor
- Elegant design • LED Light Source • Decorative Lampshades To Enhance Beauty
- Electroplated Finish • Exceptional Airflow • Innovative Design
- Incredibly Quiet • 2 Years Warranty

ITEM CODE	SWEEP	WATTAGE	SPEED	AIR DELIVERY
SCFZ 101448	1200 mm	40W	330 RPM	220 CMM

- HIGH GRADE COPPER
- NOISELESS OPERATION
- WOOD FINISH BLADES
- 3 COLOUR LED LIGHT
- ELECTROPLATED FINISH

- MORE STARS MORE SAVINGS POWER SAVINGS GUIDE
- PREMIUM QUALITY GUARANTEED



Antique Brass/Wood



Antique Copper Rose Wood



IMPERIAL LOOKS.
CLASSY PERFORMANCE.

Elegantly carved Daisy ceiling fans are a perfect combination of form and function! The fan looks imperial with striking features and decorative lampshades. It is equipped with a super quiet copper motor and electroplated blades that guarantees brilliant airflow. Available in two wood finish & electroplated, the fan can also be operated with a remote. The Daisy fan is a luxury that you can't miss adding to your living room.

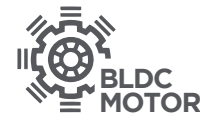

PHANTOM

SUPER DECORATIVE CEILING FAN

The Phantom super decorative fan is a delightful mix of classical and modern styles and adds an extra dimension to your decor. It offers exciting features like six blades and an under-light that can glow in three colours and different brightness levels. The Phantom is available in three antique finishes and can be operated with a remote.



Antique Brass Dark Wood



Antique Silver Dark Wood



Antique Copper Rose Wood

PRODUCT HIGHLIGHTS

- Incredibly Quiet • 3 Colour LED With Remote • Amazingly Efficient • Exceptional Air Flow
- Elegant Design To Complement Room Decor • 2 Years Warranty

ITEM CODE	SWEEP	WATTAGE	SPEED	AIR DELIVERY
SCFZ 100148	1200 mm	40W	330 RPM	220 CMM



The Perfect Wings of Joy



VIOLA
Super Decorative Ceiling Fan

PRODUCT HIGHLIGHTS

- Incredibly Quiet • Simple & Classic Design
- Ribbed Blades For Better Strength • Superior Electroplated Finish
- Aerodynamic Profile Blades For Silent Operations • 2 Years Warranty

ITEM CODE	SWEEP	WATTAGE	SPEED	AIR DELIVERY
SCFZ 101748	1200 mm	52W	350 RPM	220 CMM



The super-efficient Voila fan is just the fan you need for your home to keep yourself cool during the summer. It is equipped with a dynamic motor for noiseless operation and ribbed blades that guarantee better air circulation. Classic in appearance due to its metallic finished blades, the Viola fan not just adds to the aesthetic appeal of your home but also ensures smooth functioning for a longer time.

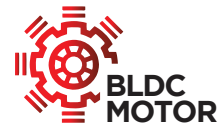

HUSH - AIR

BLDC SUPER DECORATIVE CEILING FAN

Enjoy the pleasure of a cool breeze in the midst of summer with the Hush-Air BLDC super decorative ceiling fans. With a powerful motor and innovative blade design, the Hush-Air offers high-speed performance, noiselessly. This incredibly efficient and amazingly stylish fan will offer excellent airflow to every corner of your room!



Coffee Brown



Satin White



American Walnut

PRODUCT HIGHLIGHTS

- Smooth & Silent Operation • Innovative & Contemporary Design • Amazingly Stylish
- High Air Delivery • ABS Decorative Blades • 2 Years Warranty

*Also available in induction motor

ITEM CODE	SWEEP	WATTAGE	SPEED	AIR DELIVERY
CFZ 100750	1250 mm	40W	280 RPM	230 CMM



Beat The Heat In Style.



Antique Steel
Wenge Wood



Antique Brass
Wenge Wood



Antique Brass



Brushed Steel



Antique Copper

GLADIATOR

Super Decorative Ceiling Fan

PRODUCT HIGHLIGHTS

- Smooth & Silent Operation
- Amazingly Efficient
- Superior Air Delivery
- High Grade Copper
- 2 Years Warranty

ITEM CODE	SWEEP	WATTAGE	SPEED	AIR DELIVERY
SCFZ 100948	1200 mm	52W	350 RPM	220 CMM



Beat the heat in style with the incredibly quiet Gladiator super decorative ceiling fans. This electroplated decorative fan with unique antique metal finishes functions as good as it looks. Fitted with a powerful motor that is enhanced with extra high grade copper, the Gladiator is your warrior to fight against the heat!



THOR

SUPER DECORATIVE CEILING FAN

The Thor ceiling fan is an example of how some of the best things in life come in small packages. A unique, four-blade fan, the Thor has an electroplated body and is available in a variety of wood finishes. Bold, fresh, stylish yet compact and minimal, the Thor has a beast of a motor that is supremely quiet yet cools the space around it in an extremely short time.



Antique Copper Rose Wood



Antique Steel Wenge Wood



Antique Brass Wenge Wood

PRODUCT HIGHLIGHTS

- Electroplated Decorative • Amazingly Efficient • Exceptional Air Flow
- High Grade Copper • 2 Years Warranty

ITEM CODE	SWEEP	WATTAGE	SPEED	AIR DELIVERY
CFZ 101124	600 mm	65W	850 RPM	105 CMM





Fluid & Synchronized Performance



Antique Copper
Rose Wood



Antique Brass
Wenge Wood



Antique Copper
Choco Brown

FLORA
Decorative Ceiling Fan

PRODUCT HIGHLIGHTS

- Incredibly Quiet • Exotic Rich Looks
- Extremely Efficient • Electroplated Ring & Trims
- 2 Years Warranty

ITEM CODE	SWEEP	WATTAGE	SPEED	AIR DELIVERY
SCFP 300348	1200 mm	52W	380 RPM	220 CMM

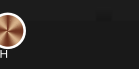
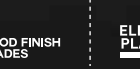

The Flora is inspired by the naturally occurring shape found in flower petals. Apart from the aesthetic appeal of these fans, their aerodynamic blade design ensures superior airflow even at low speeds which makes them more energy efficient than conventional fans. These fans also create lower air turbulence and wind noise and are the ideal option for modern interiors.



HERO PRIME
Decorative Ceiling Fan

SOPHISTICATED STYLE

Brilliant Performance



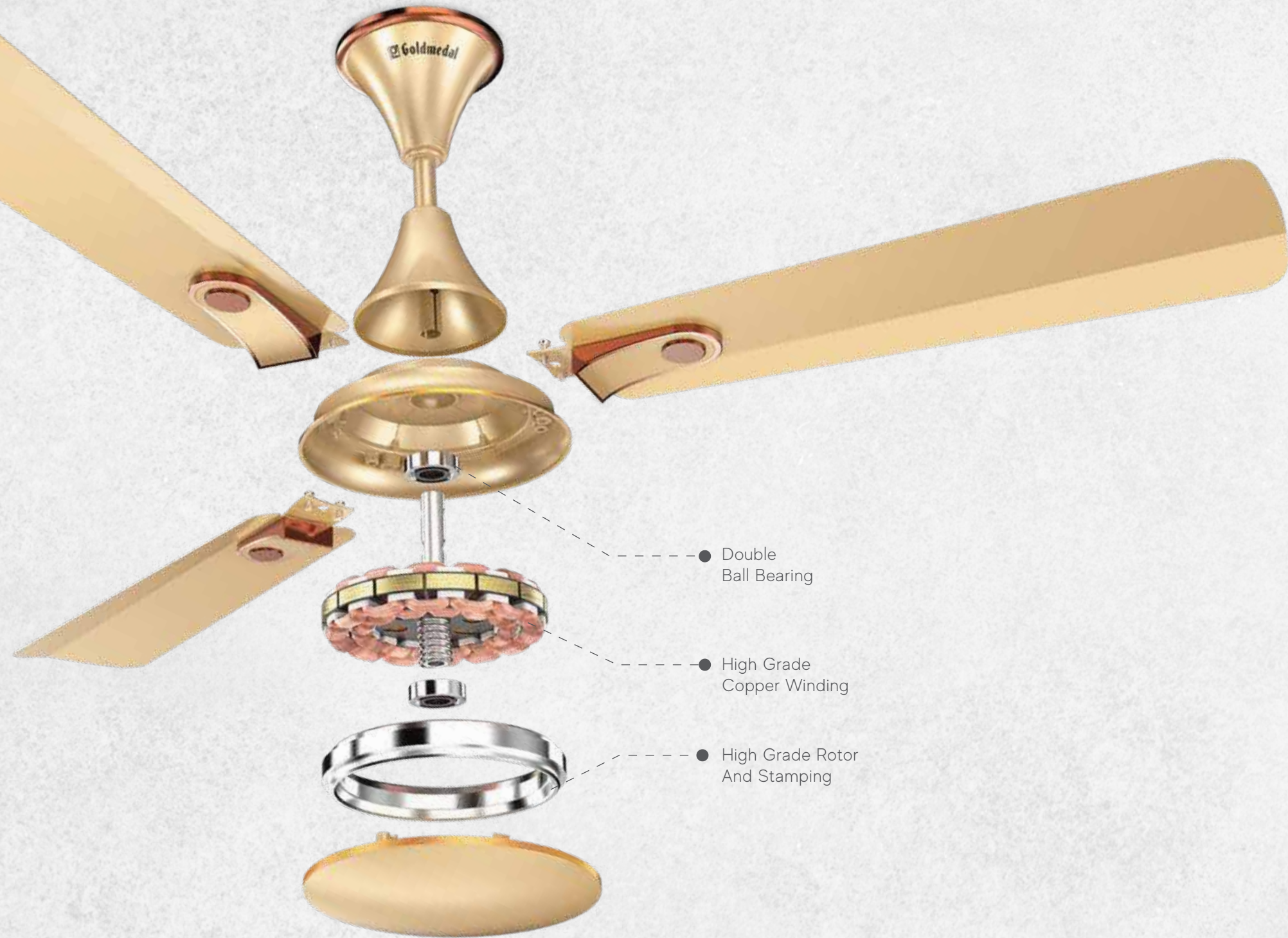

- Double Ball Bearing
- High Grade Copper Winding
- High Grade Rotor And Stamping



HERO PRIME

Decorative Ceiling Fan

PRODUCT HIGHLIGHTS

- Incredibly Quiet
- Wider Blade For Better Air Thrust
- Amazingly Efficient
- Elegant Design With Stylish Trims
- Superior Metallic Paint Finish

ITEM CODE	SWEEP	WATTAGE	SPEED	AIR DELIVERY
SCFP 301548	1200 mm	54W	380 RPM	230 CMM

The Hero Prime is a stylish yet practical fan that can perform silently in all conditions. Its aluminum blades and compact body are coated with superior, anti-corrosive metallic finish paint that enables the fan to maintain its high-gloss look for years. With a powerful motor, the Hero Prime ensures a lifetime of trouble-free use.

INSIGNIA
Decorative Ceiling Fan

Designed for efficiency
in cool, exciting designs





INSIGNIA

DECORATIVE CEILING FAN

The Insignia decorative fan is a stylish solution to beat the scorching heat of the summer months. Meticulously designed with premium fittings, the Insignia is an aerodynamically superior fan that offers excellent air flow while being extremely quiet and efficient. Available in five exciting shades, the Insignia makes you look and feel cooler!



Espresso Brown



Angel White



Topaz Gold



Indigo Blue



Carbon Black

PRODUCT HIGHLIGHTS

- Incredibly Quiet • Bold Design For Modern Homes • Extremely Efficient • Exceptional Air Flow
- Superior Metallic Paint Finish • High Grade Copper • 2 Years Warranty

ITEM CODE	SWEEP	WATTAGE	SPEED	AIR DELIVERY
SCFP 300548	1200 mm	52W	380 RPM	225 CMM





A MODERN DESIGN
For Stylish Homes



HOOPLA

Decorative Ceiling Fan

PRODUCT HIGHLIGHTS

- Incredibly Quiet • Elegant Design • Amazingly Efficient
- Exceptional Air Flow • High Grade Copper
- Superior Metallic Paint Finish • 2 Years Warranty

ITEM CODE	SWEEP	WATTAGE	SPEED	AIR DELIVERY
SCFP 301136	900 mm	45W	450 RPM	140 CMM
SCFP 301148	1200 mm	50W	380 RPM	225 CMM



The shimmering and sophisticated Hoopla decorative ceiling fan is as good as it looks. In the classic combination of delicate metallic rings on motor with a premium embellishment on the blades, the Hoopla is designed to suit contemporary tastes and modern homes. With its high energy efficiency and powerful performance, the Hoopla will liven up your room as well as your spirits!



The new definition of
Timeless Elegance

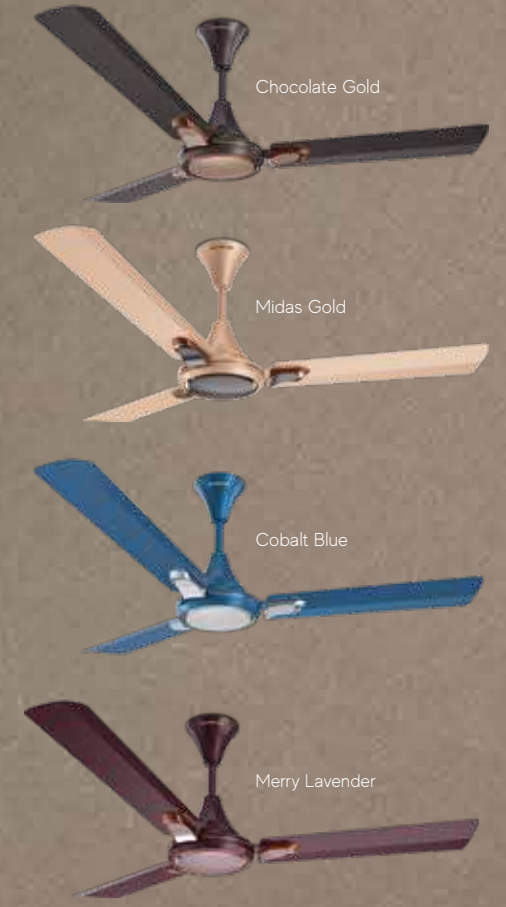

SENORA
Decorative Ceiling Fan

PRODUCT HIGHLIGHTS

- Incredibly Quiet • Dual Tone Finish
- Amazingly Efficient • Exceptional Air Flow
- High Grade Copper • 2 Years Warranty

ITEM CODE	SWEEP	WATTAGE	SPEED	AIR DELIVERY
SCFP 300948	1200 mm	50W	380 RPM	220 CMM

DOUBLE BALL BEARING
 HIGH GRADE COPPER
 NOISELESS OPERATION
 WITH EXTRA COPPER
 LONG LASTING COAT

ANTI DUST
 MORE STARS MORE SAVINGS POWER SAVINGS GUIDE
 PREMIUM QUALITY GUARANTEED

There are fans that stand out, and then there is the Senora that spells class from every angle. Designed for modern, contemporary lifestyles, the Senora can be a star fitting in most Indian homes. Its fluid-shaped trimmings contrast eloquently with its body colour, making it a truly mesmerizing sight. Adding to its allure is its anti-dust feature that makes the Senora maintain its superior finish for a really long time. For all its beauty, the Senora is a truly efficient fan, delivering effective cooling on demand.



EVA PRIME

DECORATIVE CEILING FAN

When you need a fan that doesn't just deliver optimum performance but also optimises the interiors of your home or office, look no further than the EVA Prime. Exquisitely finished in superior paint, the EVA Prime stands out from the rest due to its rich, exclusive shades. The trimmings on this high-quality fan are minimal, yet noticeable in a contemporary manner. Its noiseless operation is another feature that makes the EVA Prime simply an outstanding piece of engineering.



Baker Brown



Royal Lavender



Denim Blue

PRODUCT HIGHLIGHTS

- Incredibly Quiet • Rich Trendy Looks • Extremely Efficient • Exceptional Air Flow
- Superior Metallic Paint Finish • High Grade Copper • 2 Years Warranty

ITEM CODE	SWEEP	WATTAGE	SPEED	AIR DELIVERY
SCFP 301748	1200 mm	50W	400 RPM	220 CMM





ENZO

DECORATIVE CEILING FAN

The Enzo offers a rich, exotic look that makes it an apt choice for trendy, modern apartments and offices. Wider, aerodynamically designed blades ensure higher airflow at lower speeds while its superior paint finish allows it to retain its classy appearance for a longer time. Like all fans in the decorative range, the Enzo has a powerful motor enhanced by high grade copper windings.



Baker Brown



Oyster White



Topaz Gold



Lavender Brown

PRODUCT HIGHLIGHTS

- Incredibly Quiet • Bold Design For Modern Homes • Extremely Efficient • Exceptional Air Flow
- Superior Metallic Paint Finish • High Grade Copper • 2 Years Warranty

ITEM CODE	SWEEP	WATTAGE	SPEED	AIR DELIVERY
CFP 301324	600 mm	65W	850 RPM	105 CMM
SCFP 301336	900 mm	45W	450 RPM	140 CMM
SCFP 301348	1200 mm	50W	380 RPM	220 CMM



Trendy & stylish.
High performance guaranteed



AIR CREST
Classic Decorative Ceiling Fan

PRODUCT HIGHLIGHTS

- Incredibly Quiet • Elegant Design • Amazingly Efficient
- Exceptional Air Flow • High Grade Copper
- Long Lasting Coat • 3 Years Warranty

ITEM CODE	SWEEP	WATTAGE	SPEED	AIR DELIVERY
SCFP 501448	1200 mm	50W	400 RPM	215 CMM



Make your summers cooler with the Air Crest decorative ceiling fan. The wide blades of this fan ensure that air is well distributed indoors. The Air Crest fan comes with a high-grade copper motor ensuring robust performance for a longer span. Designed for elegance, the Air Crest fan is available in attractive colors to blend well with any décor.



AIRAVAT DX

CLASSIC DECORATIVE CEILING FAN

Sleek, sophisticated, and powerful – the Airavat DX is the perfect example of a fan built for optimum performance and discreet elegance. The premium gloss trimmings on the blades juxtaposed with the clean, straight lines of the fan and the delicate metallic rings on the motor adds a bit of poise to its overall presence.



Tangy Brown



White



Ivory

PRODUCT HIGHLIGHTS

- Incredibly Quiet • Bold Design For Modern Homes • Extremely Efficient • Exceptional Air Flow
- Long Lasting Coat • High Grade Copper • 2 Years Warranty

ITEM CODE	SWEEP	WATTAGE	SPEED	AIR DELIVERY
SCFS 501548	1200 mm	52W	400 RPM	220 CMM





AIRAVAT

CLASSIC CEILING FAN

True to its name, the Airavat ceiling fan comes with a powerful motor and efficient blades that ensures quick and efficient cooling of any room. The use of high grade copper windings, rotor, and stamping allows the Airavat to optimally function at high speeds for a very long time. The classic design makes it suitable for any kind of interior.



Tangy Brown



White



Ivory

PRODUCT HIGHLIGHTS

- Incredibly Quiet • Bold Design For Modern Homes • Extremely Efficient • Exceptional Air Flow
- Long Lasting Coat • High Grade Copper • 2 Years Warranty

ITEM CODE	SWEEP	WATTAGE	SPEED	AIR DELIVERY
SCFS 501248	1200 mm	52W	400 RPM	220 CMM



A perfect blend of
Style & Performance



VECTOR
Classic Decorative Ceiling Fan

PRODUCT HIGHLIGHTS

- Incredibly Quiet • Elegant Design
- Amazingly Efficient • Exceptional Air Flow
- Long Lasting Coat • 2 Years Warranty

ITEM CODE	SWEEP	WATTAGE	SPEED	AIR DELIVERY
SCFS 500848	1200 mm	50W	400 RPM	210 CMM

DOUBLE BALL BEARING HIGH GRADE COPPER NOISELESS OPERATION LONG LASTING COAT HIGH SPEED

ULTRA HIGH SPEED 400 RPM MORE STARS MORE SAVINGS POWER SAVING GUIDE PREMIUM QUALITY GUARANTEED

The Vector decorative ceiling fans will blow you away with their unmatched performance. With a powerful motor and aerodynamic blades, the fan promotes a wider conical spread of breeze to ensure air distribution in each and every corner of the room. Designed to perform optimally even at lower voltages, the Vector is a long-lasting robust fan.



GATI DECO

CLASSIC DECORATIVE CEILING FAN

True to its name, the Gati Deco ceiling fan maximizes the airflow in your home with its robust motor and lightweight blades. As sophisticated as it looks, the fan performs efficiently even as it delivers ultra-high speed breeze. Simple yet elegant in looks, the Gati Deco is enhanced with delicate metallic rings on the motor that adds poise and grace to the rooms.



Brown



White



Ivory



Smoke Brown

PRODUCT HIGHLIGHTS

- Incredibly Quiet • Bold Design For Modern Homes • Extremely Efficient • Exceptional Air Flow
- Long Lasting Coat • High Grade Copper • 2 Years Warranty

ITEM CODE	SWEEP	WATTAGE	SPEED	AIR DELIVERY
SCFS 500348	1200 mm	50W	400 RPM	210 CMM



DOUBLE BALL BEARING



HIGH GRADE COPPER



NOISELESS OPERATION



HIGH SPEED



LONG LASTING COAT



ULTRA HIGH SPEED
400 RPM



MORE STARS
MORE SAVINGS
POWER SAVINGS GUIDE



PREMIUM QUALITY
GUARANTEED

LEGACY 390
Classic Ceiling Fan

PRODUCT HIGHLIGHTS

- Ultra High Speed • Clean Sophisticated Design
- Amazingly Efficient • Better Air Circulation • 2 Years Warranty

ITEM CODE	SWEEP	WATTAGE	SPEED	AIR DELIVERY
SCFS 501348	1200 mm	52W	400 RPM	225 CMM



BRING HOME COMFORT &
HIGH PERFORMANCE



Truly living up to its name, the Legacy 390 is an elegantly designed, super-efficient fan! While wider blades promise better air distribution, the powerful motor of this fan ensures ultra-high speed up to 400 RPM. Available in Metallic Brown, Matt White, and Pearl Ivory shades, the Legacy 390 blends smoothly with the aesthetics of your home.

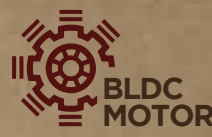

GEO FOX

BLDC Classic Ceiling Fan

PRODUCT HIGHLIGHTS

- Remote Control Operation For Fan On/Off & Speed Control
- Exotic Rich & Trendy Looks
- 60% More Efficient Than Conventional Fans
- Optimum Air Flow Even At Low Voltage
- No Humming Sound While Running On Invertor
- 2 Years Warranty

ITEM CODE	SWEEP	WATTAGE	SPEED	AIR DELIVERY
CFS 500948	1200 mm	35W	350 RPM	220 CMM



Ultra Performance BLDC MOTOR

Powered by a brushless DC motor, the Geo Fox ceiling fan operates quietly and efficiently, delivering high air volume while conserving energy.

- Double Ball Bearing
- Electronic Speed Controller
- 100% Copper Motor Integrated Magnetic Design
- Permanent Magnet Rotor
- IR Sensor Unit



Go green with the remote-controlled Geo-Fox BLDC ceiling fans that can save up to 60% of energy consumption! Low in maintenance, these BLDC fan's motor is made of high-quality copper and world-class bearings that ensure longevity. The Geo Fox produces no heat and can perform seamlessly even at low voltage and power fluctuation.

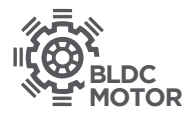

LUX FLOW

BLDC CLASSIC CEILING FAN

Upgrade your home with the eco-friendly Lux Flow BLDC ceiling fans for optimal airflow. This remote-operated fan is powered by a premium copper motor and double-ball bearings for noiseless and uninterrupted performance ensuring longer shelf life. Available in exotic rich colors, the trendy Lux Flow fan is the perfect way to enrich your house aesthetically.



Brown



White



Ivory

PRODUCT HIGHLIGHTS

- Remote Control Operation For Fan On/Off & Speed Control
- Exotic Rich & Trendy Looks • 60% More Efficient Than Conventional Fans • Optimum Air Flow Even At Low Voltage
- No Humming Sound While Running On Inverter • 2 Years Warranty

ITEM CODE	SWEEP	WATTAGE	SPEED	AIR DELIVERY
SCFS 500448	1200 mm	32W	350 RPM	220 CMM





GATI 400

STANDARD CEILING FAN

A high-speed fan, the Gati 400 lives up to its name perfectly. Delivering effective cooling in the most efficient manner, the Gati 400 is a must-have fan for those who value performance over everything else. Perfectly finished in superior paint, this fan delivers noiseless air even at a high 400 RPM. With its essential styling and powerful performance, the Gati 400 deserves to be a part of every Indian home.



Brown



White



Ivory



Smoke Brown



Matt Brown

PRODUCT HIGHLIGHTS

- Ultra High Speed • Clean Sophisticated Design • Amazingly Efficient
- Better Air Circulation • High Grade Copper • 2 Years Warranty

ITEM CODE	SWEEP	WATTAGE	SPEED	AIR DELIVERY
CFE 700224	600 mm	65W	850 RPM	105 CMM
SCFE 700236	900 mm	45W	450 RPM	140 CMM
SCFE 700248	1200 mm	50W	400 RPM	210 CMM



VEGAH 400
Standard Ceiling Fan

PRODUCT HIGHLIGHTS

- Ultra High Speed • Clean Sophisticated Design
- Amazingly Efficient • Better Air Circulation • 2 Years Warranty

ITEM CODE	SWEEP	WATTAGE	SPEED	AIR DELIVERY
SCFE 700148	1200 mm	50W	400 RPM	210 CMM



Simple, Classic With
Seamless Air Delivery...



The VegaH 400 ceiling fan is your true partner in helping you stay cool during summer. The fan is fitted with a powerful motor that performs optimally to ensure high air delivery. The wider blades ensure the air is distributed evenly throughout the room. Classy in looks, the VegaH 400 is available in four cool shades.



AIR GT

STANDARD CEILING FAN

Make your summers breezy and cool with the ultra-high-speed Air GT ceiling fan. Simple yet elegant, this fan comes with a powerful motor that is capable of delivering noiseless air even at a speed of 400 RPM. With a superior paint finish that keeps the fan looking new, the Air GT ceiling fan is a perfect combination of style and powerful performance.



Brown



White



Ivory

PRODUCT HIGHLIGHTS

- Ultra High Speed • Clean Sophisticated Design • Amazingly Efficient
- Better Air Circulation • High Grade Copper • 2 Years Warranty

ITEM CODE	SWEEP	WATTAGE	SPEED	AIR DELIVERY
SCFE 700448	1200 mm	50W	400 RPM	210 CMM





VOLT 400

STANDARD CEILING FAN

Bring home the ultra-high-speed Volt 400 to make your summers cooler and more pleasant. An efficient performer, the elegantly styled Volt 400 has a powerful motor that delivers better air circulation. Available in six shades with a superior paint finish, this fan is not only aesthetically appealing but also stays new for longer time.



PRODUCT HIGHLIGHTS

- Ultra High Speed • Clean Sophisticated Design • Amazingly Efficient
- Better Air Circulation • High Grade Copper • 2 Years Warranty

ITEM CODE	SWEEP	WATTAGE	SPEED	AIR DELIVERY
CFS 501648	1200 mm	50W	400 RPM	210 CMM





TABLE | WALL | PEDESTAL

These are a must-have in any home or office that becomes warm on a regular basis. Powerful, quiet, and extremely energy-efficient, Goldmedal table/wall/pedestal fans deliver amazing cooling as per your need. With their smooth oscillations, multiple speed options, and height as well as head position adjustments, these fans are the ideal solution when you feel the need for a cool breeze. Their superior construction and powerful motor ensures years of trouble-free service. Available in multiple sizes, shapes, and attractive colours, these fans from Goldmedal are a delight to use.



TRICOOL

Pedestal Fan

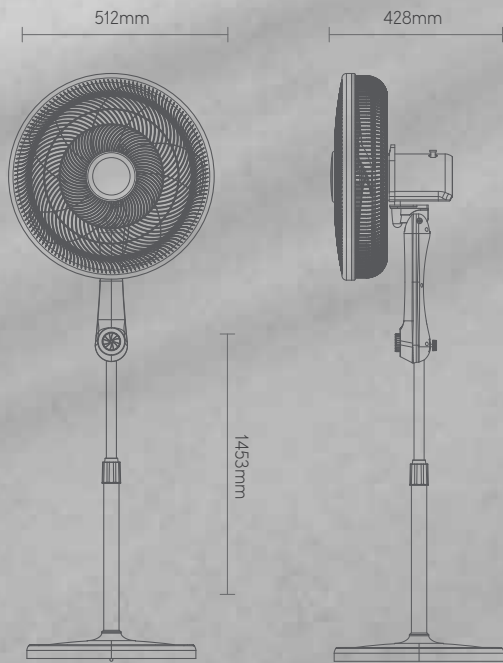

Don't miss out on Tricool, a multipurpose 3-in-1 electric fan that can be used as a pedestal, wall, and table fan. The high-speed performance fan is supported by aerodynamic blades for noiseless operation. Brilliantly designed, the energy-efficient Tricool fans are powered by a copper motor for improved air distribution.



ITEM CODE	SWEEP	WATTAGE	SPEED	AIR DELIVERY
LFP 800118	450 mm	80W	1350 RPM	105 CMM



PRODUCT HIGHLIGHTS

- ABS Plastic Body
- Easily washable & cleanable
- 3 In 1 (Pedestal, Wall & Table)
- Plastic Blades For Silent Operation
- Composition 60% Plastic & 40% Metal
- Jerk Free Oscillation
- Telescopic Height Adjustment
- High Grade Copper





New Definition Of Silence

ADORA

Wall Fan

ITEM CODE	SWEEP	WATTAGE	SPEED	AIR DELIVERY
WFP 200716	400 mm	55W	1200 RPM	90 CMM



Goldmedal
SWITCH TO THE AMAZING



Grey

PRODUCT HIGHLIGHTS

- Self Lubricating Motor • Wide-sweep Oscillation
- Powerful & Efficient • Double Ring Metal grill
- Free Neck Device • High Grade Material with 5 Leaf SAN Blades

There is so much to adore about the Adora wall fan. From its whisper-quiet performance, self lubricating motor to its powerful and efficient 5 leaf SAN blade design, Adora is the wall fan that you need. It has a double ring metal grill for sturdy operation and wide-sweep oscillation for maximum air delivery. It is a free-neck device, which allows easy vertical adjustment. The adorable Adora is available in a classical single grey colour.

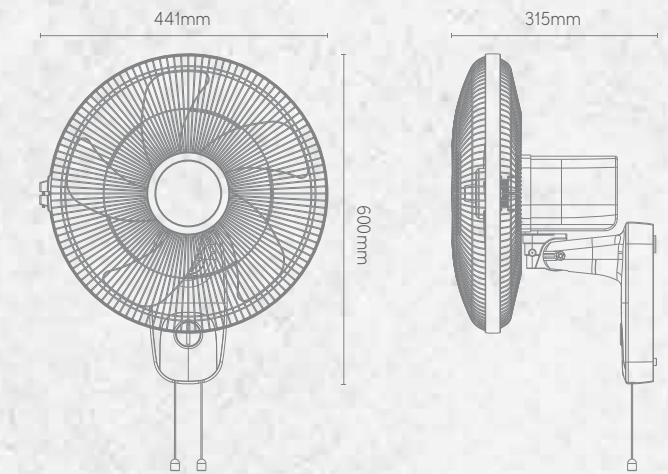

NORA

Table Fan

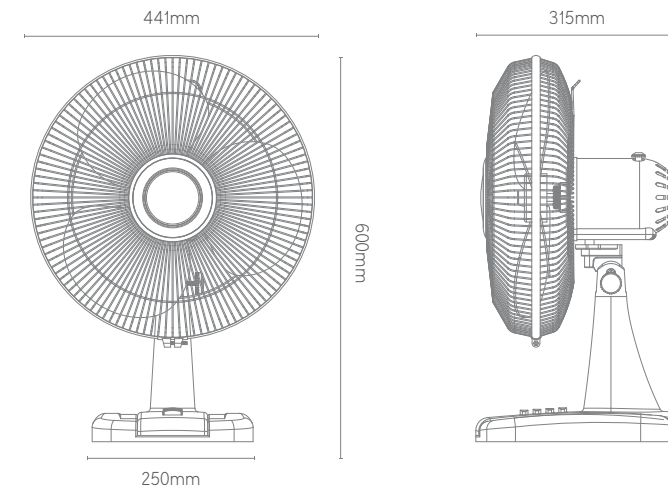

The Nora is a premium table fan that is designed to last long while looking good. The ABS blades of Nora allows it to provide better air delivery and the corrosion resistant powder coated metal guards protect it from rust formation. This high-speed fan comes with a synchronous motor and thermo cut-off protection for the best cooling experience. It has a broad base for stability and a 3-speed controller for optimizing your cooling needs.

ITEM CODE	SWEEP	WATTAGE	SPEED	AIR DELIVERY
TFS 153516	400 mm	110W	2100 RPM	100 CMM

- ENERGY EFFICIENT
- 3 SPEED CONTROLLER
- BROAD BASE
- AERODYNAMIC BLADE ANGLES
- CRMO STAMPING
- SYNCHRONOUS MOTOR

PRODUCT HIGHLIGHTS

- ABS Blades
- Synchronous Motor
- Thermo Cut-off Protection
- High Grade Copper
- Powder Coated Metal Guards

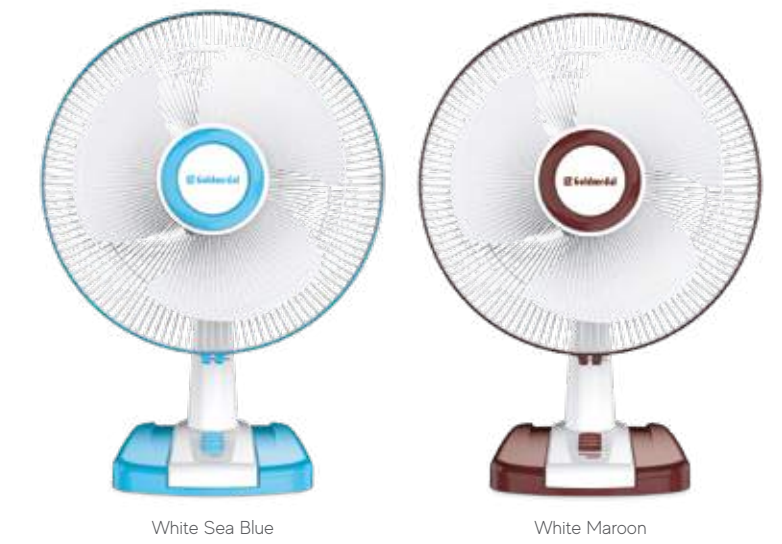

ERICA
Table Fan

Performance that
Brings on a Smile



ITEM CODE	SWEEP	WATTAGE	SPEED	AIR DELIVERY
TFS 150616	400 mm	55W	1300 RPM	75 CMM

ENERGY EFFICIENT | 3 SPEED CONTROLLER | BROAD BASE | AERODYNAMIC BLADE ANGLES | CRNO STAMPING

PRODUCT HIGHLIGHTS

- Plastic Blades
- Jerk Free Oscillation
- Powerful Motor
- High Grade Copper
- Powder Coated Metal Guards

The Erica has features that make it one of the best table fans in the market. It has plastic blades that ensure silent operation and powder coated metal guards that prevent corrosion. Even with a powerful motor and high-speed performance, the Erica oscillates smoothly and silently. The Erica is available in two attractive colours- White Sea Blue and White Maroon.



White Sea Blue



White Maroon

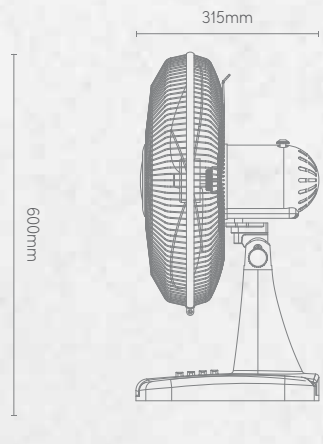
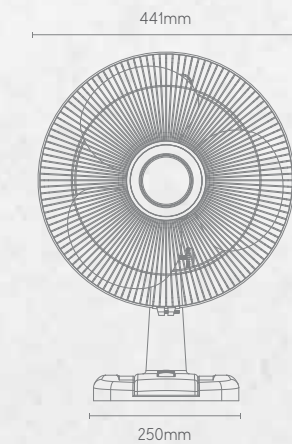

NORA

Wall Fan

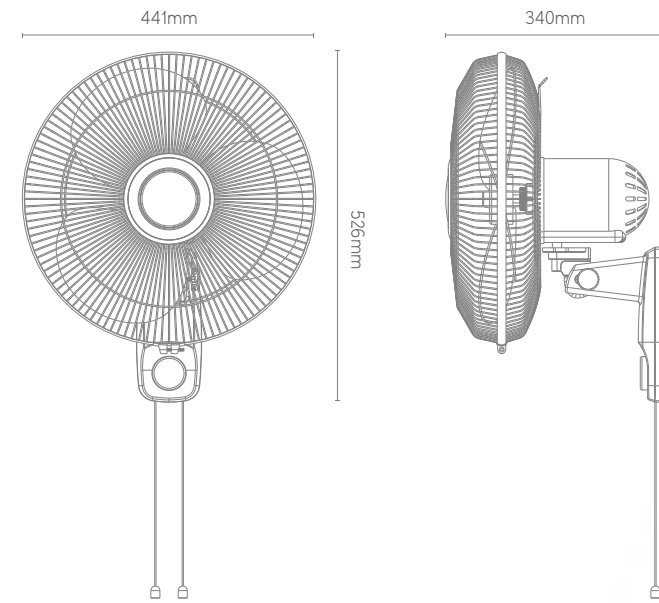

The Nora high-speed wall fan is powered by a synchronous motor and offers thermo cut-off protection. With a classic design, the Nora is not only easy to install on to the wall but also effortless to use. The Nora is suitable for homes, offices or any other space and can be installed without any hassle. Like other wall fans by Goldmedal, it is energy efficient, has three-speed controller and is available in three colour options.

ITEM CODE	SWEEP	WATTAGE	SPEED	AIR DELIVERY
WFS 253512	300 mm	65W	2300 RPM	70 CMM
WFS 253516	400 mm	110W	2100 RPM	100 CMM

3 SPEED CONTROLLER
 HIGH SPEED
 AERODYNAMIC BLADE ANGLES
 CRNG STAMPING
 SYNCHRONOUS MOTOR

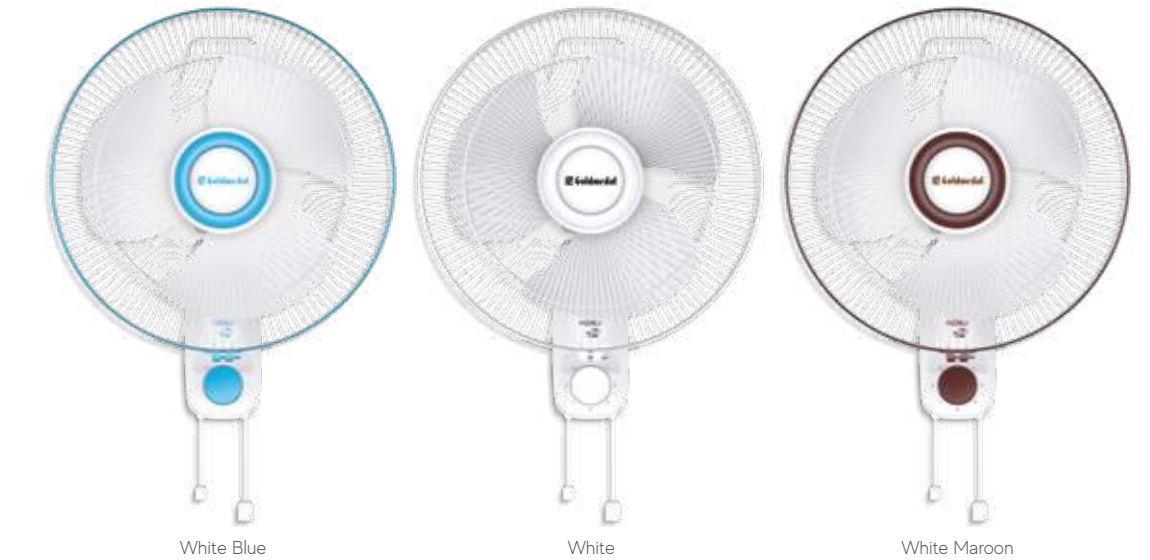

PRODUCT HIGHLIGHTS

- 300 mm PP Blade
- 400 mm ABS Blade
- Thermo Cut-off Protection
- High Grade Copper
- Powder Coated Metal Guards
- Synchronous Motor



ERICA

Wall Fan

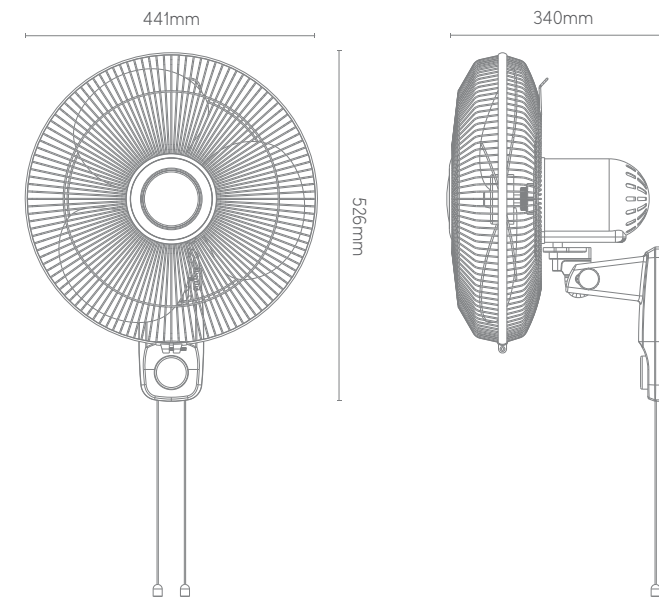

ITEM CODE	SWEEP	WATTAGE	SPEED	AIR DELIVERY
WFS 250516	400 mm	55W	1300 RPM	75 CMM

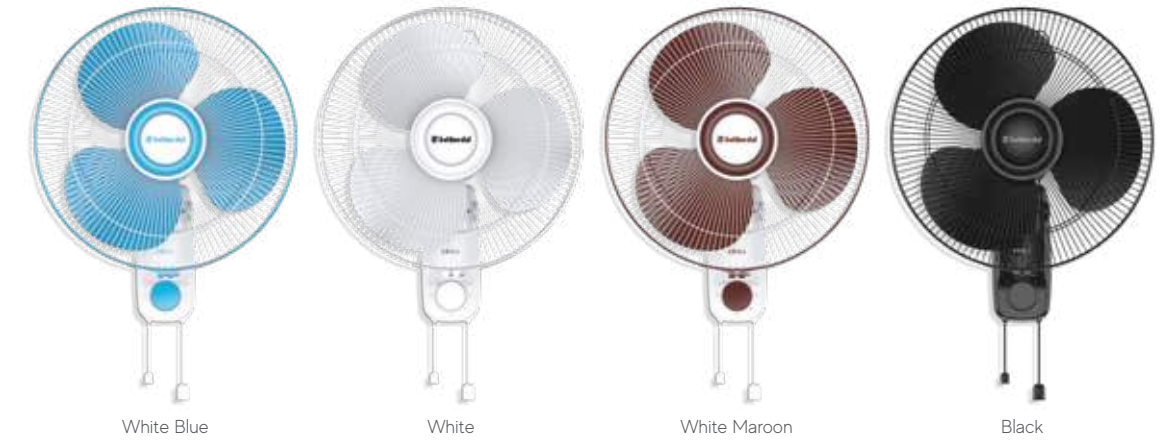

PRODUCT HIGHLIGHTS

- Plastic Blades
- Silent Operation
- Synchronous Motor
- High Grade Copper
- Powder Coated Metal Guards

Simple yet stylish, silent yet powerful, the Erica wall fan is the perfect cooling accessory for your wall. It is made with plastic blades for silent operation and corrosion resistant powder coated metal guards for a rust-free look. Like all wall fans by Goldmedal, it is energy efficient, has three-speed controller and can be easily installed onto the wall.



OLIVIA

Wall Fan

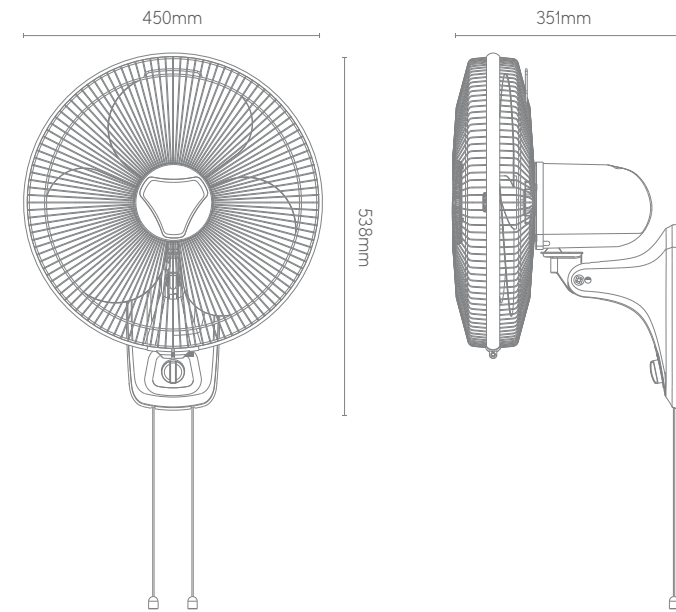

Inspired by minimalistic design aesthetics, the Olivia is an amazing wall fan that looks as good as it cools. With a simple and refined presence, Olivia features lightweight plastic blades that ensure noiseless, jerk free operation even at higher speed settings. The corrosion resistant powder coated metal guards are sturdy and safe to use. Available in two classic colour options, Olivia wall fans set a high standard for wall fans.

ITEM CODE	SWEEP	WATTAGE	SPEED	AIR DELIVERY
WFS 252516	400 mm	60W	1325 RPM	70 CMM

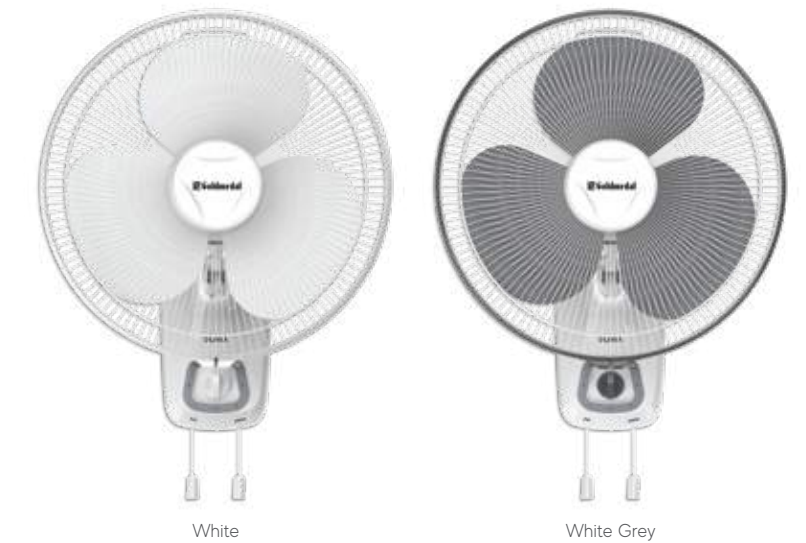

PRODUCT HIGHLIGHTS

- Plastic Blades
- Silent Operation
- Jerk-Free Oscillation
- High Grade Copper
- Powder Coated Metal Guards



OLIVIA PRO

Wall Fan

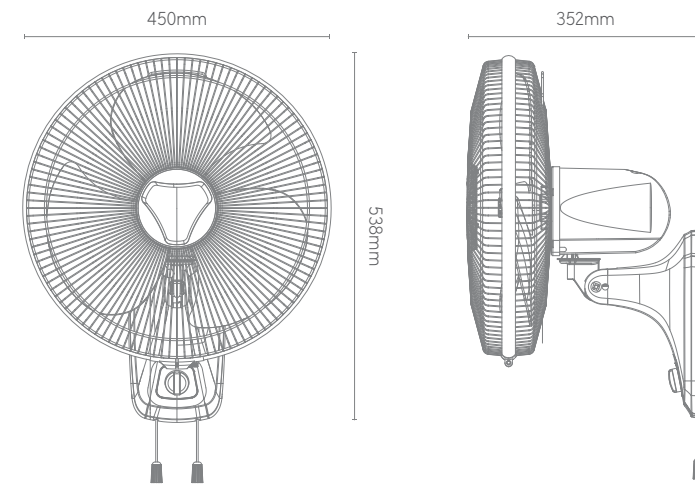

A high-speed wall fan that delivers a stream of cool breeze in a noiseless manner, the Olivia Pro wall fan is as good as it gets. It has a superior, refined presence on the wall while its plastic blades and corrosion resistant powder coated metal guards ensures that its look will endure over the years. The fan also has an in-built Thermo Cut-off that shuts down the fan in case of high voltage supply. Available in two attractive colours, the Olivia Pro wall fan will be a wonderful addition to any home or office.

ITEM CODE	SWEEP	WATTAGE	SPEED	AIR DELIVERY
WFS 250316	400 mm	125W	2100 RPM	90 CMM



White



White Grey

PRODUCT HIGHLIGHTS

- Plastic Blades
- Jerk-Free Oscillation
- Thermo Cut-off Protection
- High Grade Copper
- Powder Coated Metal Guards



GLORIA

Wall Fan

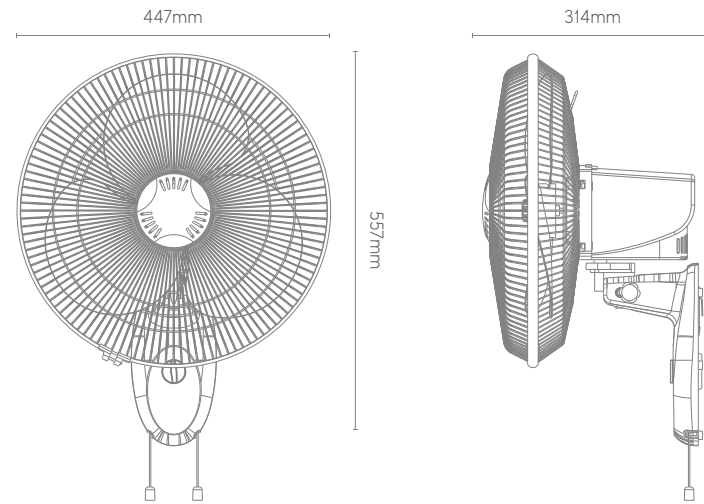

Feel fresh and cool with the wall-mounted Gloria fans at your homes or offices. Thanks to the powerful motor, aerodynamic blades, speed, and oscillation controllers, the Gloria wall fans are excellent at removing warm air and cooling rooms instantly. The corrosion-resistant metal guard ensures that the fan appears new for a longer span of time.

ITEM CODE	SWEEP	WATTAGE	SPEED	AIR DELIVERY
WFS 250616	400 mm	55W	1350 RPM	70 CMM

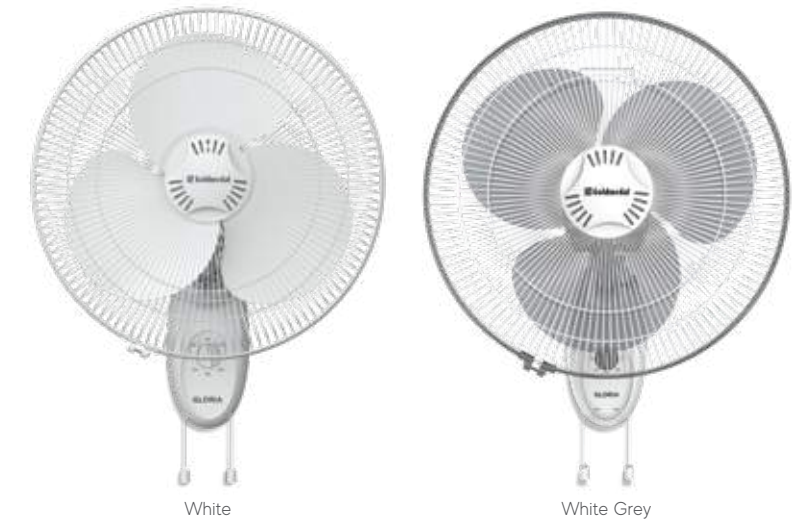

PRODUCT HIGHLIGHTS

- Plastic Blades With Silent Operation
- High Grade Copper
- Corrosion Resistant Powder Coated Metal Guards
- Jerk Free Oscillation



DYNO

Wall Fan

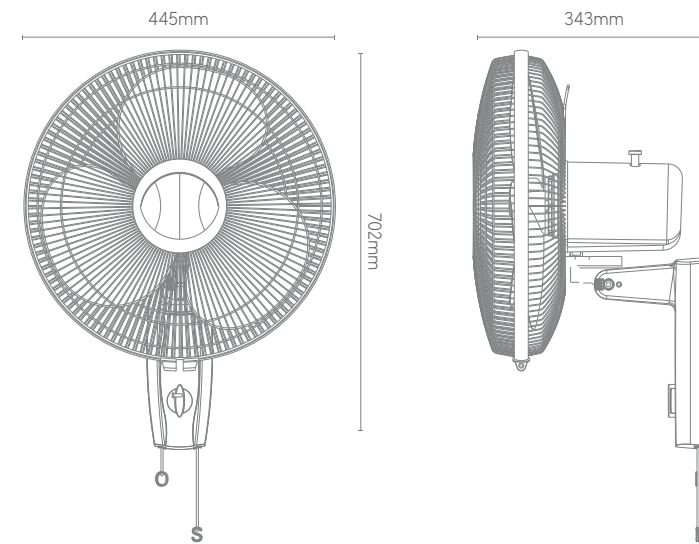

ITEM CODE	SWEEP	WATTAGE	SPEED	AIR DELIVERY
WFS 250716	400 mm	55W	1350 RPM	70 CMM

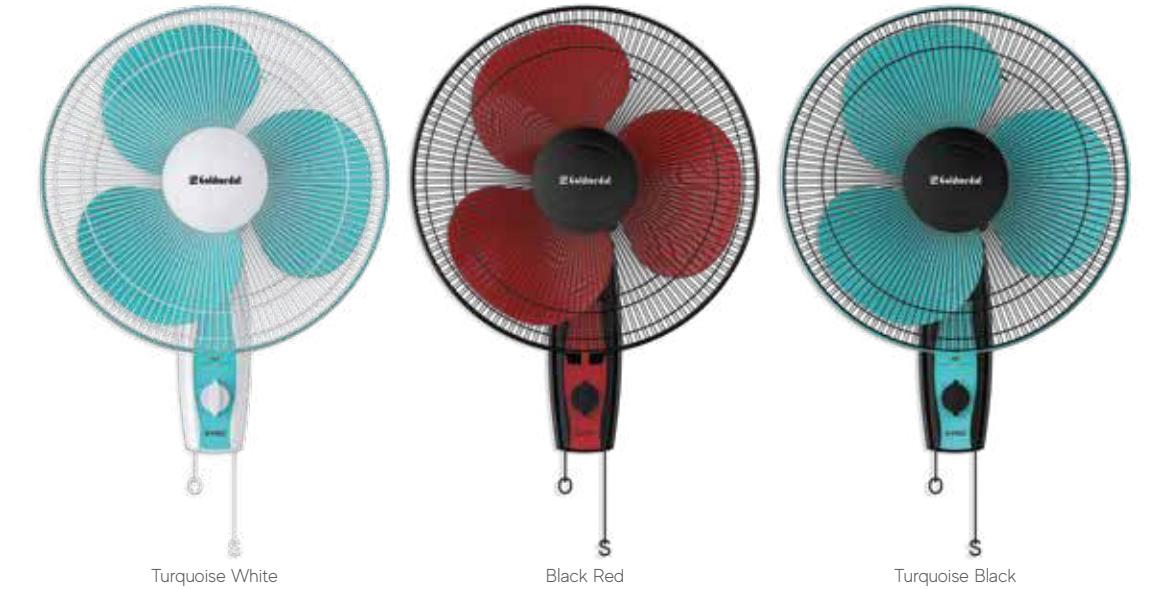

Don't sweat this summer; get the Dyno wall fans to stay cool! Easy to mount, the Dyno wall fan operates quietly and efficiently with aerodynamic blades and a high-powered motor. With the 3-speed switch control and uniform oscillation, Dyno is a stylish and effective way to keep your home cool.

PRODUCT HIGHLIGHTS

- Plastic Blades With Silent Operation
- High Grade Copper
- Corrosion Resistant Powder Coated Metal Guards
- Jerk Free Oscillation



DYNO PRO

Wall Fan

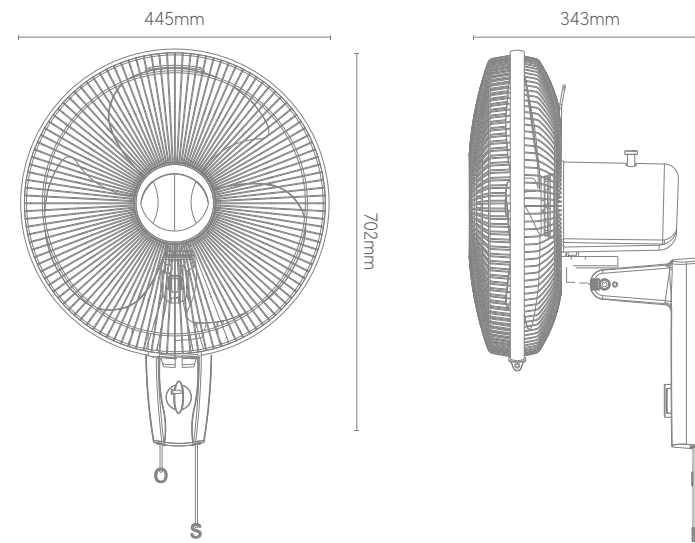

The Dyno Pro wall fan is designed to perform super-efficiently to keep your home cool. While its aerodynamic plastic blades deliver a cool breeze, they also add to the aesthetics of your interiors with their body-contrasting colours. In addition, the easy tilt setting and jerk-free oscillation makes the Dyno Pro one of the best wall fans to keep you super-cool during summers.

ITEM CODE	SWEEP	WATTAGE	SPEED	AIR DELIVERY
WFS 250416	400 mm	110W	2100 RPM	90 CMM

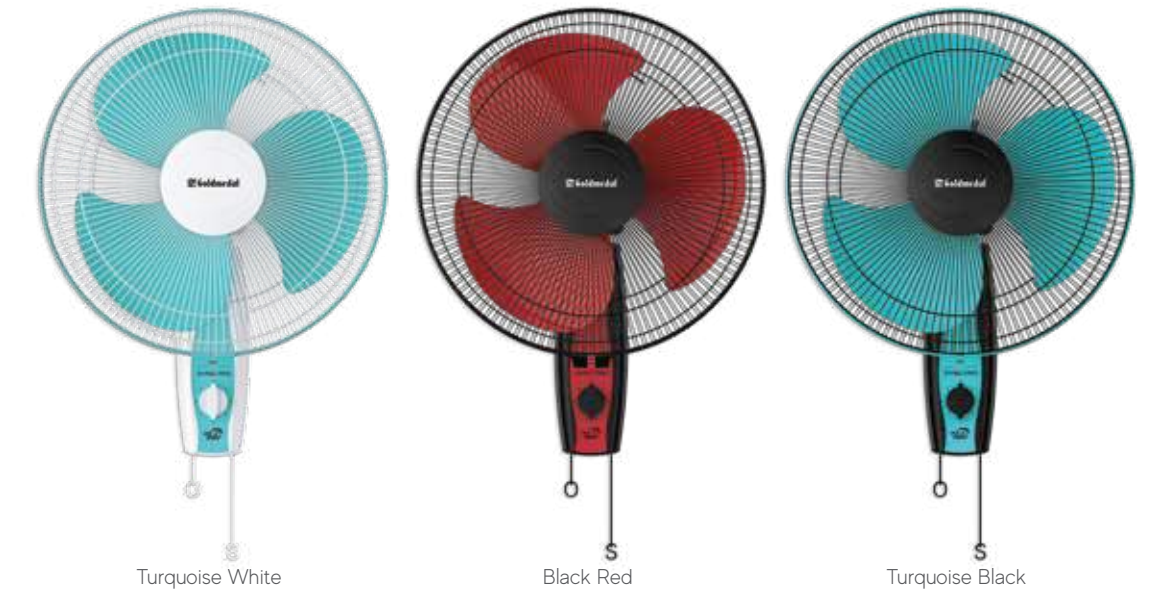

PRODUCT HIGHLIGHTS

- Plastic Blades With Silent Operation
- High Grade Copper
- Corrosion Resistant Powder Coated Metal Guards
- Jerk Free Oscillation



G-EXPRESS

Wall Fan

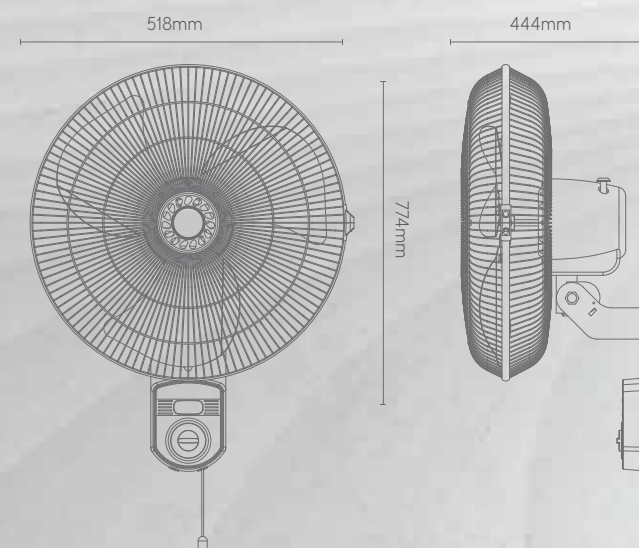

Stay cool with the super-efficient G-Express wall fan. With a powerful motor and aerodynamic blade angles, this fan is the perfect way to cool down your bedrooms, offices, patio, or garage. Thanks to its adjustable head, multiple-speed controller, and oscillation, the G-Express offers customizable airflow as per individual needs. Classic in looks, this fan is not just efficient but also long-lasting with powder-coated metal guards and aluminium blades.

ITEM CODE	SWEEP	WATTAGE	SPEED	AIR DELIVERY
WFS 200618	450 mm	90W	1350 RPM	100 CMM



Black Silver



Black

PRODUCT HIGHLIGHTS

- High Grade Copper
- Aluminum Blades With Silent Operation
- Jerk Free Oscillation
- Thermal Overload Protection
- Smooth Neck Tilttable Movement





GLORIA

Pedestal Fan

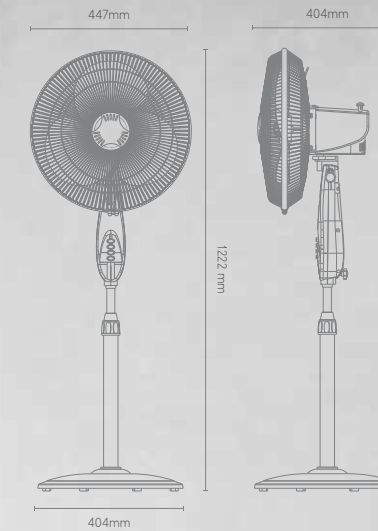

ITEM CODE	SWEEP	WATTAGE	SPEED	AIR DELIVERY
PFS 400616	400 mm	55W	1350 RPM	70 CMM

- HIGH GRADE COPPER
- NOISELESS OPERATION
- AERODYNAMIC BLADE ANGLES
- HIGH AIR DELIVERY
- SUPERIOR PAINT FINISH

PRODUCT HIGHLIGHTS

- High Grade Copper
- Jerk Free Oscillation
- Telescopic Height Adjustment
- Plastic Blades For Silent Operation
- Corrosion Resistant Powder Coated Metal Guards

The Gloria is an elegant pedestal fan with aerodynamically designed blades for better air delivery. The fan is supported by a synchronous motor to ensure quiet and smooth functioning. Designed to run for a longer time, the Gloria fans also include a three-speed controller, an oscillation controller, and a telescopic height adjuster.





NORA

Pedestal Fan

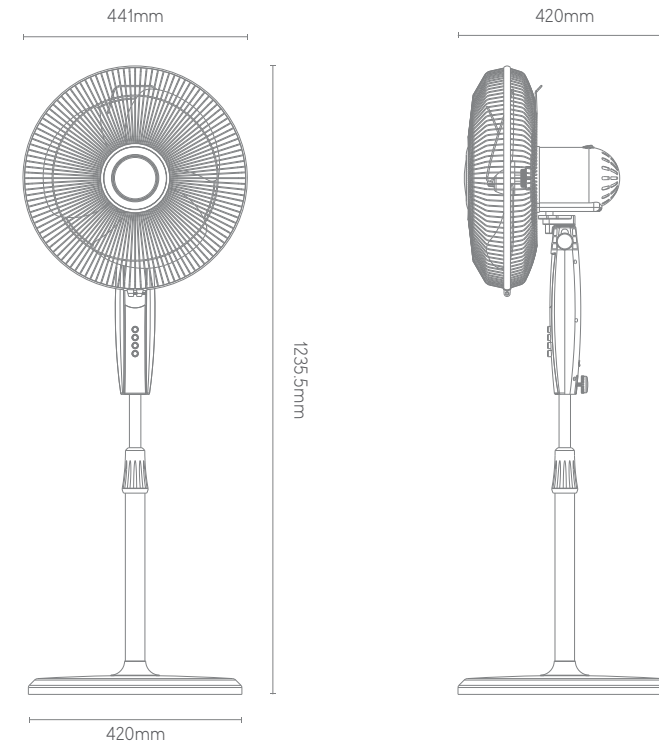

The Nora is a lightweight and ergonomically designed fan packed with some great features. It has ABS blades for better air delivery, a synchronous motor for powerful yet efficient performance and corrosion resistant powder-coated metal guards for longevity. There is no better fan to beat the Indian summer heat in style than the Nora pedestal fan!

ITEM CODE	SWEEP	WATTAGE	SPEED	AIR DELIVERY
PFS 403516	400 mm	110W	2100 RPM	75 CMM



PRODUCT HIGHLIGHTS

- ABS Decorative Blades
- Incredibly Quiet
- High Air Delivery
- Amazingly Stylish
- Innovative & Contemporary Design



ERICA

Pedestal Fan

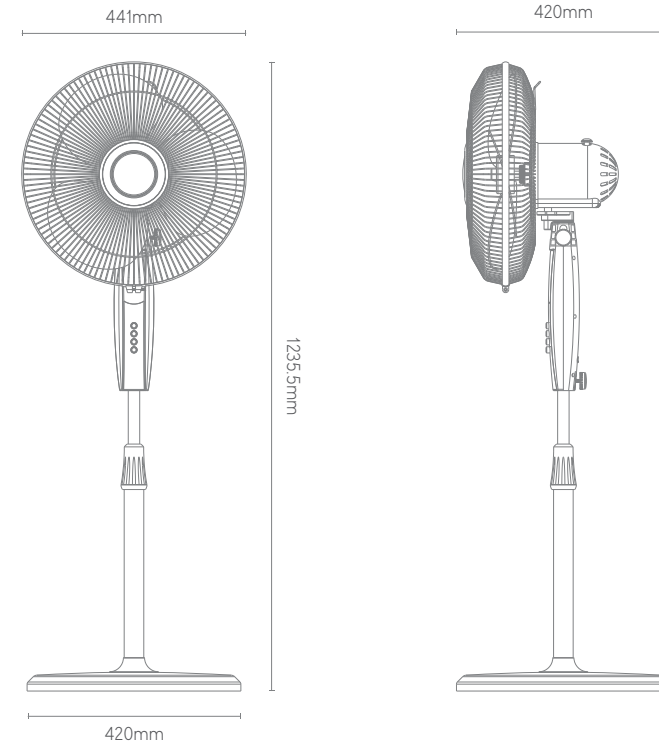

ITEM CODE	SWEEP	WATTAGE	SPEED	AIR DELIVERY
PFS 400516	400 mm	55W	1300 RPM	75 CMM



White Sea Blue White White Maroon Black Grey

PRODUCT HIGHLIGHTS

- Plastic Blades
- Silent Operation
- Jerk-Free Oscillation
- High Grade Copper
- Powder Coated Metal Guards
- Telescopic Height Adjustment

Powerful, quiet and extremely energy efficient, the Erica pedestal fan is a must-have in every Indian home and office. With its smooth oscillation, multiple speed options and telescopic height adjustment, the Erica is an ideal solution when you feel the need for a cool breeze! Available in four attractive colour options, the Erica pedestal fans are incredibly stylish and cool!





OLIVIA

Pedestal Fan

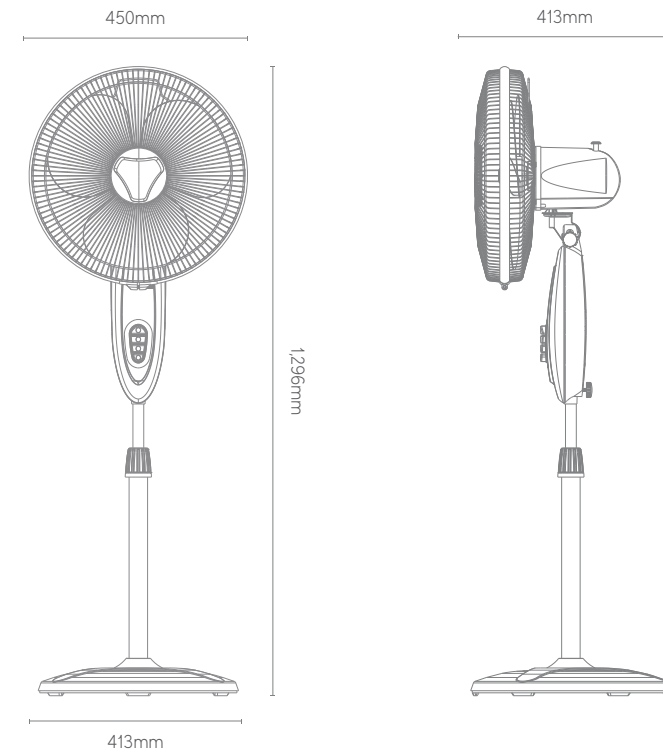

Stylish, portable, and efficient, Olivia pedestal fan is a must-have cooling device in every modern Indian home. It offers you a gush of cool air instantly yet silently. With features like telescopic height adjustment, multiple speed settings, and jerk-free oscillation, Olivia pedestal fans are convenient and amazing to use. Available in three attractive colours, these pedestal fans are a class apart.



ITEM CODE	SWEEP	WATTAGE	SPEED	AIR DELIVERY
PFS 402516	400 mm	60W	1325 RPM	70 CMM



PRODUCT HIGHLIGHTS

- Plastic Blades
- Silent Operation
- Jerk-Free Oscillation
- High Grade Copper
- Powder Coated Metal Guards
- Telescopic Height Adjustment





OLIVIA PRO

Pedestal Fan

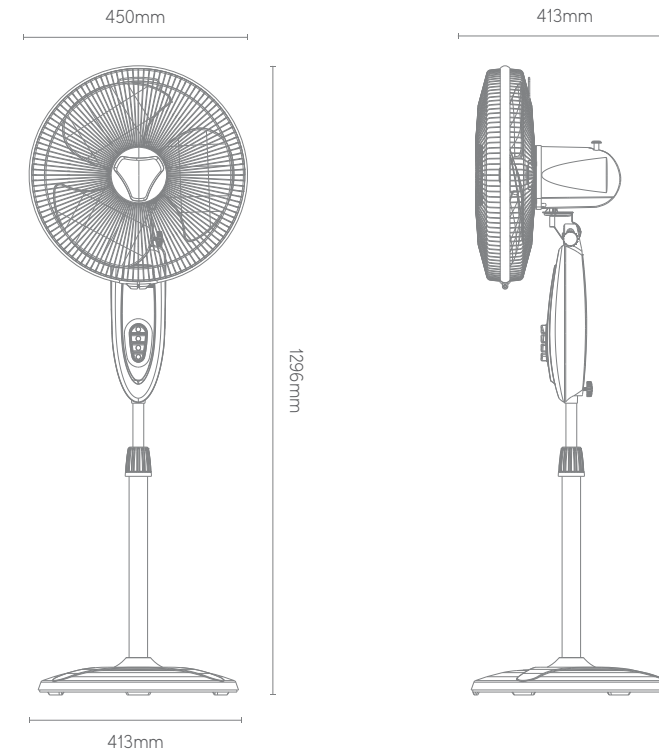

The Olivia Pro pedestal fan is not just a stylish and efficient cooling device, it is also supremely reliable and practical. Apart from necessary features like telescopic height adjustment, multiple speed settings, jerk-free oscillation, and corrosion-resistant, powder coated metal guards, Olivia Pro also has in-built thermo cut-off that shuts down the fan in case of high voltage supply. The Olivia Pro is available in attractive colours to ensure that it can complement your interiors.



ITEM CODE	SWEEP	WATTAGE	SPEED	AIR DELIVERY
PFS 400316	400 mm	125W	2100 RPM	90 CMM



White Green White White Grey

PRODUCT HIGHLIGHTS

- Plastic Blades
- Silent Operation
- Jerk-Free Oscillation
- High Grade Copper
- Powder Coated Metal Guards
- Telescopic Height Adjustment





DYNO

Pedestal Fan

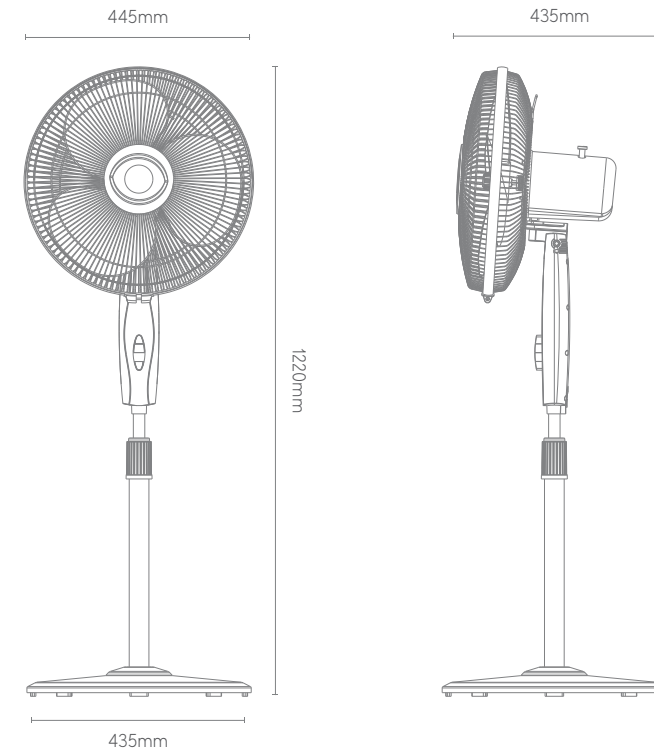

Keep your homes cool with the ultra-quiet, strong, and energy-efficient Dyno pedestal fans. These fans perform without any hitch thanks to their smooth oscillation and numerous speed settings with head and height position adjustments. The Dyno fans are not only sturdy but also fashionable and are available in a variety of lovely colors.

ITEM CODE	SWEEP	WATTAGE	SPEED	AIR DELIVERY
PFS 400716	400 mm	55W	1350 RPM	70 CMM



PRODUCT HIGHLIGHTS

- High Grade Copper
- Jerk Free Oscillation
- Telescopic Height Adjustment
- Plastic Blades With Silent Operation
- Corrosion Resistant Powder Coated Metal Guards



Turquoise White

Black Red

Turquoise Black





DYNO PRO

Pedestal Fan

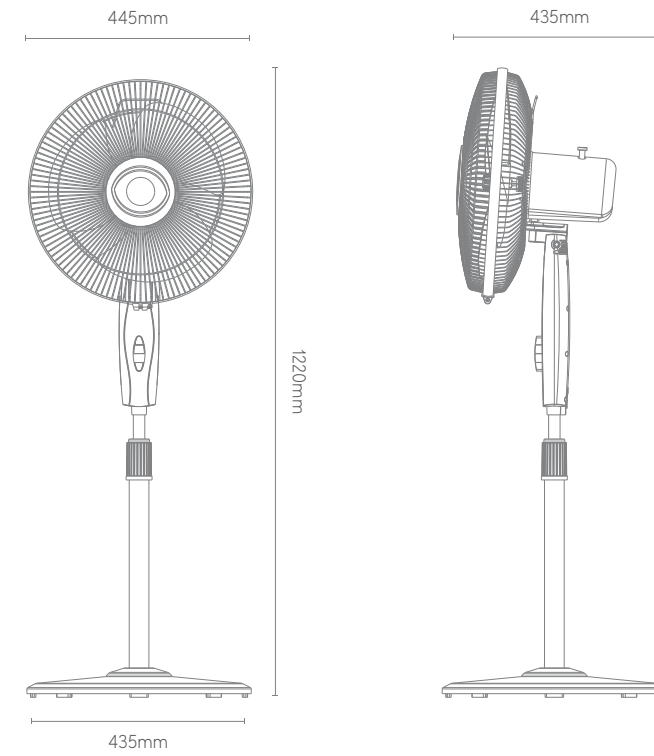

Super-stylish, efficient, and easy to operate is what makes the Dyno Pro pedestal fan a must for every household during the warmer months. Easily portable, this fan delivers high speed to keep you cool and comfortable with a robust motor. The Dyno Pro fan is not only aesthetically appealing but also designed to perform seamlessly for years.



ITEM CODE	SWEEP	WATTAGE	SPEED	AIR DELIVERY
PFS 400416	400 mm	110W	2100 RPM	90 CMM



PRODUCT HIGHLIGHTS

- High Grade Copper
- Jerk Free Oscillation
- Telescopic Height Adjustment
- Plastic Blades For Silent Operation
- Corrosion Resistant Powder Coated Metal Guards





G-EXPRESS

Pedestal Fan

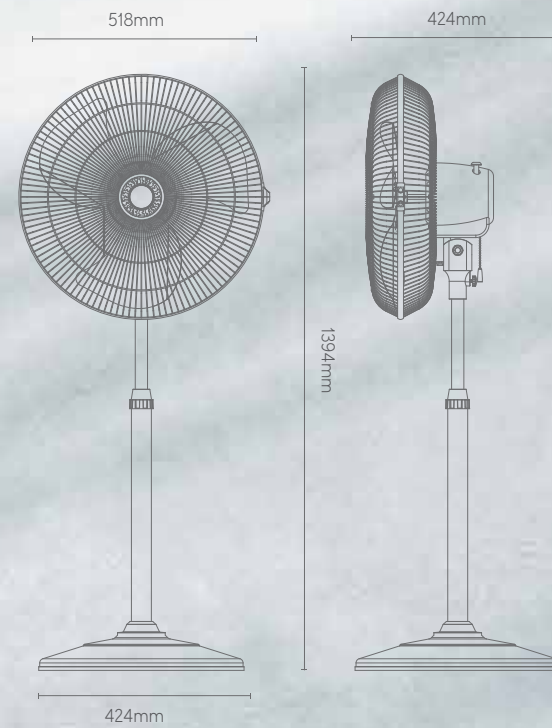

ITEM CODE	SWEEP	WATTAGE	SPEED	AIR DELIVERY
FFS 550618	450 mm	90W	1350 RPM	100 CMM

- ENERGY EFFICIENT
- 3 SPEED CONTROLLER
- BROAD BASE
- AERODYNAMIC BLADE ANGLES
- POWERFUL MOTOR

Comfort is guaranteed when you have the G Express pedestal fans by your side that promises super cool breeze. These pedestal fans are supported by a super quiet motor and aluminum blades which make the fans rust free thus improving their performance and longevity. G Express fans can also be vertically adjusted up to 30 degrees in addition to 90-degree oscillation for better air delivery.

PRODUCT HIGHLIGHTS

- Aluminium Blades
- Silent Jerk Free Operation
- Telescopic Height Adjustment
- High Grade Copper
- Powder Coated Metal Guards



Black Silver

Black





FALCON

Pedestal Fan

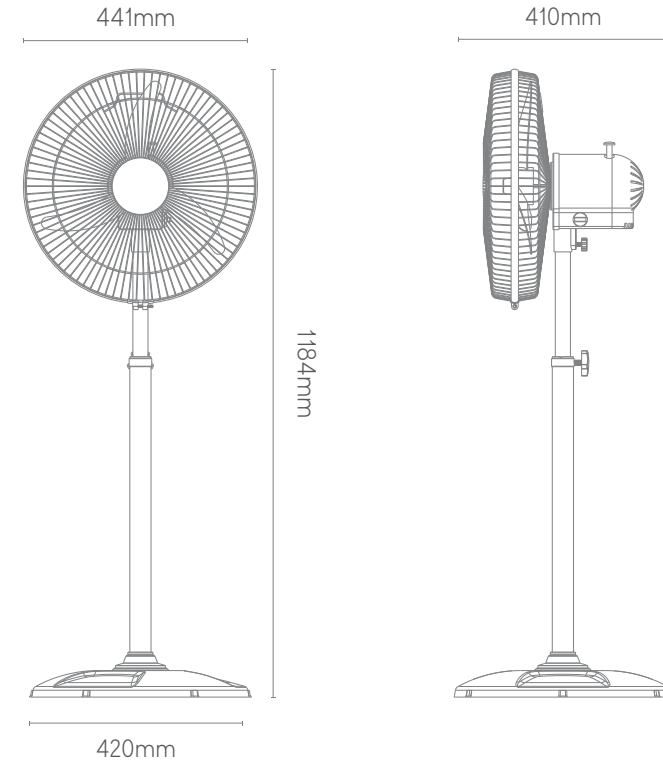

If you're looking for a sophisticated, stylish and modern pedestal fan for your home, the Falcon mini farata fan is undoubtedly the best choice. This wide-base fan offers jerk-free oscillation and super smooth operation. The Falcon also features aerodynamic metal blades that offer superior air delivery and three-modes of operation for added convenience.



Black Yellow

Black Silver

ITEM CODE	SWEEP	WATTAGE	SPEED	AIR DELIVERY
FFS 550316	400 mm	105W	2100 RPM	125 CMM



PRODUCT HIGHLIGHTS

- Rich & Modern Style
- Jerk-free Oscillation & Smooth functioning
- Powder Coated Guards
- Aerodynamic ABS Blades
- Three Modes of Operation





FARATA

Pedestal Fan



ITEM CODE	ITEM NAME	SWEEP	WATTAGE	SPEED	AIR DELIVERY
FFS 550720	Torpedo	500 mm	140W	1350 RPM	100 CMM
FFS 550820	Turbo Storm	500 mm	140W	1350 RPM	100 CMM

- ENERGY EFFICIENT
- 3 SPEED CONTROLLER
- BROAD BASE
- AERODYNAMIC BLADE ANGLES

PRODUCT HIGHLIGHTS

- Modern Design
- Powder Coated Guards
- Sturdy Iron Cast Base
- Aerodynamic Metal Blades
- Three Modes of Operation

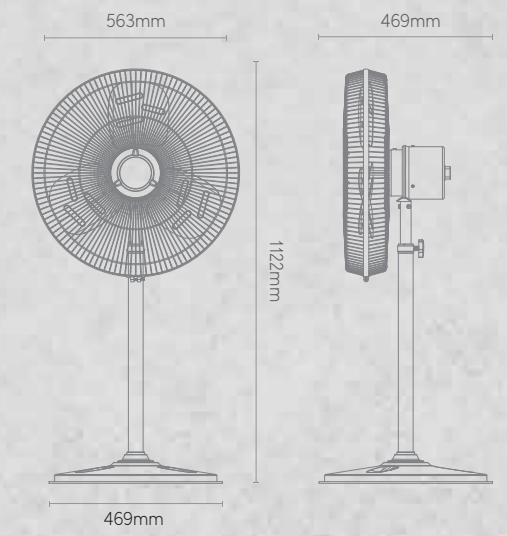

Metallic Grey

**HEAVY-DUTY PERFORMANCE FOR
MAXIMUM AIR CIRCULATION**

In search of a heavy-duty yet stylish farata fan? Look no further. The Farata is a modern and sturdy farata fan with an iron cast base that keeps the fan stable as it delivers high speed air! The aerodynamic metal blades are coated with corrosion resistant powder so that they last longer. The Farata is available with three modes of operation for added convenience.





ASTOR

Cabin Fan



ITEM CODE	SWEEP	WATTAGE	SPEED	AIR DELIVERY
PCS 650212	300 mm	75W	2200 RPM	60 CMM

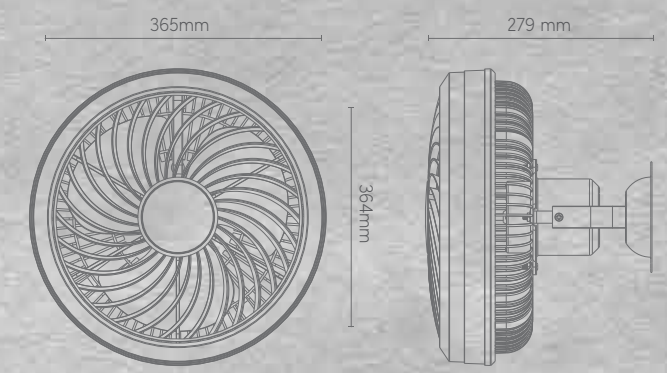

- ENERGY EFFICIENT
- DOUBLE BALL BEARING
- HIGH SPEED
- POWERFUL MOTOR
- HIGH AIR DELIVERY
- SUPERIOR PAINT FINISH



White Grey

The Astor cabin fans can be a rich addition to your homes and offices. This compact and sturdy fan comes with a powerful motor to provide breezy and cool air. The Astor fans can move flexibly for better air delivery while their visually appealing protective grill keeps the user secure from any accidental touch. Easy to carry and fit, the Astor fans can be easily installed in rooms or cabins that demand quick cooling.

PRODUCT HIGHLIGHTS

- PP Blades
- Incredibly Quiet
- High Air Delivery
- Amazingly Stylish
- Innovative & Contemporary Design





TRISTAR

Personal Fan

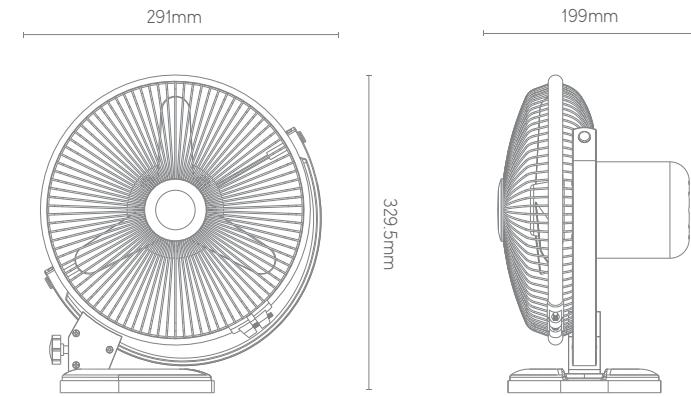

This power-packed mini personal fan is everything you will ever need in a fan. It is compact, energy-efficient and delivers air at high speed, giving you instant relief from the hot weather. Longevity is guaranteed as the Tristar is made with high-grade copper and coated with metallic finish. Available in cool Black-Yellow & Black-Grey and white-grey colour combinations, the Tristar is designed to make a style statement!

ITEM CODE	SWEEP	WATTAGE	SPEED	AIR DELIVERY
PCS 650909	225 mm	45W	2200 RPM	25 CMM



PRODUCT HIGHLIGHTS

- Energy Efficient
- Powder Coated Metallic Finish
- Powerful Motor
- High Grade Copper
- Compact Design



Black-Grey



Black-Yellow



A X I A L | V E N T I L A T I O N

Bad odour, fine dust particles, fumes, and pollen can quickly deteriorate air quality. The Goldmedal axial and ventilation fans swiftly exhaust contaminated and toxic hot air out of the room while consuming less energy and creating even lesser noise. The axial fans feature superior air suction technology that ensures clean fresh air at all times. With blades that are designed for faster rotation and noiseless operation, these super-efficient ventilation fans offer proper air circulation. So bid goodbye to bad odour, smoky and foggy rooms!

www.goldmedalindia.com



FROST PRIME | FROST

Axial Fan



Frost Prime



Frost



Boost your interiors with Frost, a powerful and ultra-modern axial fan that offers powerful air suction for clean and fresh air delivery. The Frost Prime comes with LED lights on the sides rendering it an uber-cool look. True to their name, the Frost fans provide a constant flow of fresh air circulation in the room.

FROST PRIME

ITEM CODE	SWEEP	WATTAGE	SPEED	AIR DELIVERY
AFP 700704	100 mm	15W	2200 RPM	75 CMH
AFP 700706	150 mm	25W	1900 RPM	236 CMH

FROST

ITEM CODE	SWEEP	WATTAGE	SPEED	AIR DELIVERY
AFP 700806	150 mm	25W	1900 RPM	236 CMH



PRODUCT HIGHLIGHTS

- Fresh ABS Plastic Material
- Better Air Suction
- Black Glass with LED Light
- Perametrical Air Extraction
- Quite & Longer Durability
- Thermo Cut-off Protection
- Smooth & Silent Operation



Rich Black



Rich Black

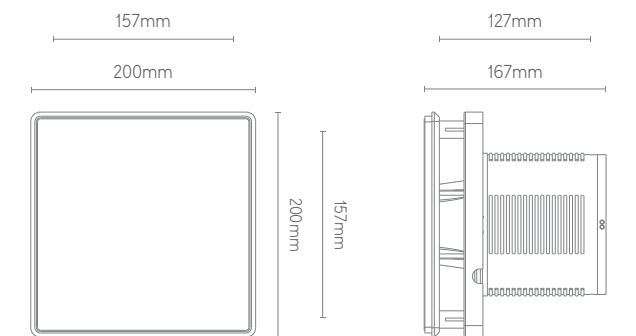

AIR VENT

Axial Fan

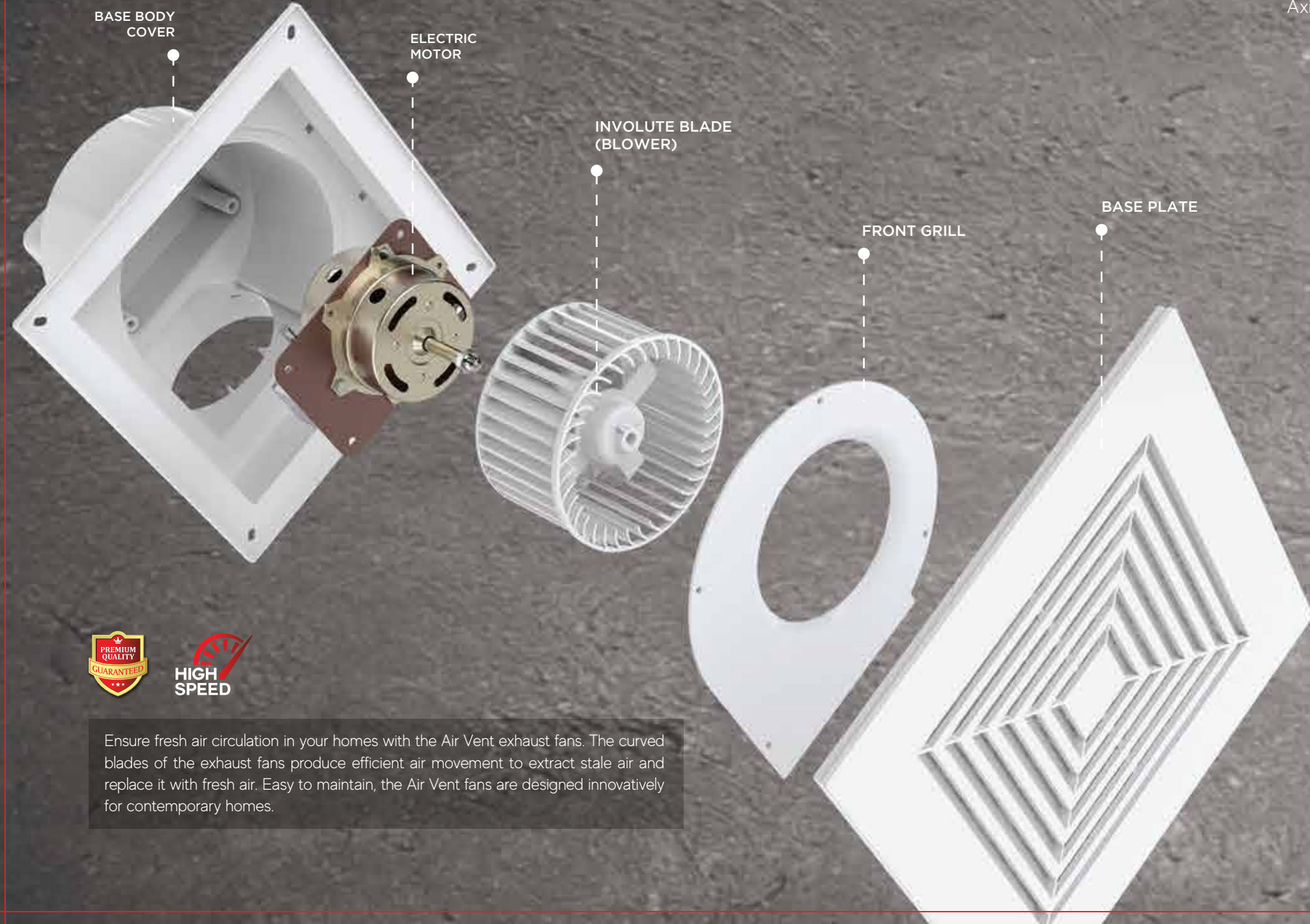

HIGH SPEED

Ensure fresh air circulation in your homes with the Air Vent exhaust fans. The curved blades of the exhaust fans produce efficient air movement to extract stale air and replace it with fresh air. Easy to maintain, the Air Vent fans are designed innovatively for contemporary homes.



White

ITEM CODE	SWEEP	WATTAGE	SPEED	AIR DELIVERY
EFP 800108	200 mm	65W	2100 RPM	750 CMH



PRODUCT HIGHLIGHTS

- Super Efficient Motor
- Detachable Front Grill
- Unique & Sleek Design
- Easy To Install
- Low Power Consumption
- Smooth & Silent Operation
- Roof/Ceiling Mounting

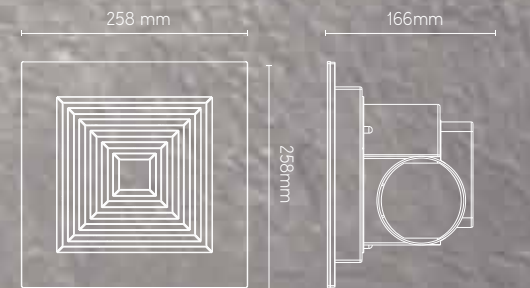



NOVA PRO | NOVA

Axial Fan



Nova Pro



Nova



The Nova axial fans are designed brilliantly for effortless suction of hot and humid air. The strong turbo motor and lightweight blades of the Nova and Nova Pro fan ensure speedy rotation which leads to fresh air delivery. The Nova Pro sports a backlit LED in addition to the wavy bird screen that goes well with modern interiors.

NOVA PRO with LED Light

ITEM CODE	SWEEP	WATTAGE	SPEED	AIR DELIVERY
AFP 701006	150 mm	18W	2300 RPM	250 CMH

NOVA

ITEM CODE	SWEEP	WATTAGE	SPEED	AIR DELIVERY
AFS 751104	100 mm	18W	2500 RPM	90 CMH
AFS 751106	150 mm	18W	2300 RPM	250 CMH
AFS 751108	200 mm	24W	2000 RPM	350 CMH



PRODUCT HIGHLIGHTS

- Super Efficient Motor • Detachable Front Grill
- Unique & Sleek Design • LED Light • Easy To Install
- Better Air Suction • Low Power Consumption
- Smooth & Silent Operation



White



White

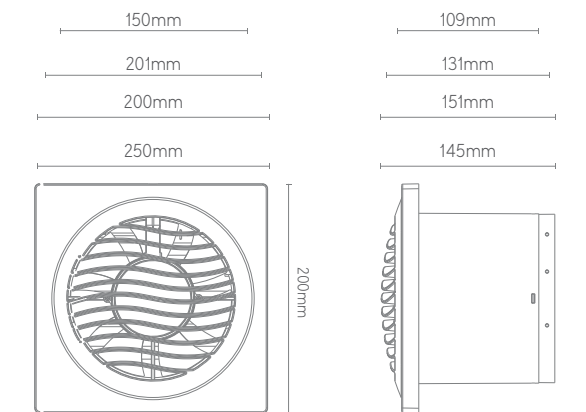

AERO

Axial Fan



ITEM CODE	SWEEP	WATTAGE	SPEED	AIR DELIVERY
AFS 750706	150 mm	25W	2250 RPM	240 CMH



White



Black



Ivory



The Aero axial fan is as sturdy as it is stylish. It is manufactured using high quality ABS plastic and comes with an LED indicator. The Aero with a circular design and super-efficient motor allows you to keep interiors fresh by venting out unpleasant smoke and odour. The Aero axial fan comes in White, Black, and Ivory shades.

PRODUCT HIGHLIGHTS

- Super Efficient Motor
- Detachable Front Panel
- Unique & Sleek Design
- Easy To Install
- Low Power Consumption
- Center LED Indicator
- Smooth & Silent Operation

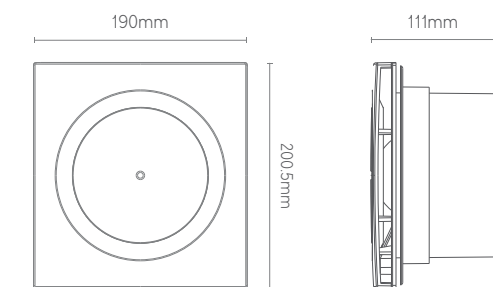

ARIA

Axial Fan



ITEM CODE	SWEEP	WATTAGE	SPEED	AIR DELIVERY
AFS 750906	150 mm	25W	2250 RPM	240 CMH

- ENERGY EFFICIENT
- POWERFUL MOTOR
- POWERFUL EXHAUST
- EASY CLEANING & MAINTENANCE
- EASY INSTALLATION



White Black Ivory

PRODUCT HIGHLIGHTS

- Super Efficient Motor
- Detachable Front Panel
- Unique & Sleek Design
- Easy To Install
- Energy Efficient
- Center LED Indicator
- Smooth & Silent Operation

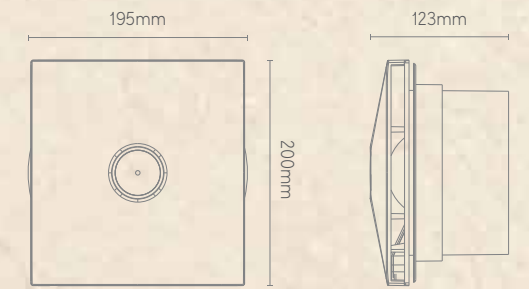

The pyramid shaped Aria axial fan is a perfect example of powerful performance combined with a trendy appearance. This high speed axial fan with strong suction power provides vibration-free ventilation ensuring that the room is free of any unpleasant odour. The Aria is available in three evergreen shades that suit every home and office.



VENTO

Axial Fan



The Vento axial fan, powered by a robust motor, ventilates the room with ease and speed. Designed using long lasting and featherlight ABS plastic, the Vento can be easily installed into your homes and offices. Adorning a classic front shield look, the Vento can effortlessly blend into the surrounding decor.



Ivory



Black

ITEM CODE	SWEEP	WATTAGE	SPEED	AIR DELIVERY
AFS 751504	100 mm	18W	2500 RPM	90 CMH
AFS 751506	150 mm	22W	1800 RPM	250 CMH
AFS 751508	200 mm	25W	2000 RPM	350 CMH



PRODUCT HIGHLIGHTS

- Super Efficient Motor
- Detachable Front Grill
- Unique & Sleek Design
- Easy To Install
- Low Power Consumption
- Smooth & Silent Operation

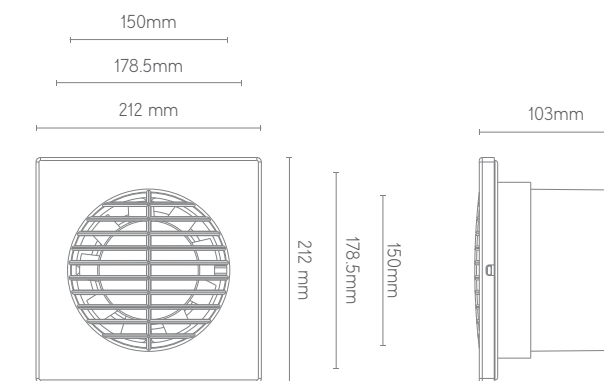

AIR-MAXX HS | AIR-MAXX

Exhaust Fan



Goldmedal

The Air Maxx HS is a powerful exhaust fan that clears hot and humid air instantly. The easy-to-install exhaust fan is supported by a highly efficient motor for smooth and silent operation. Designed to complement modern homes, the Air Maxx HS comes with a dust protection shutter for long-lasting performance.



AIR-MAXX HS

ITEM CODE	SWEEP	WATTAGE	SPEED	AIR DELIVERY
EFS 850506	150 mm	40W	2500 RPM	500 CMH
EFS 850508	200 mm	65W	2100 RPM	750 CMH

AIR-MAXX

ITEM CODE	SWEEP	WATTAGE	SPEED	AIR DELIVERY
EFS 850306	150 mm	35W	1350 RPM	280 CMH
EFS 850308	200 mm	38W	1300 RPM	550 CMH
EFS 850310	250 mm	40W	1250 RPM	750 CMH



White

Black

Ivory

PRODUCT HIGHLIGHTS

- Super Efficient Motor
- Dust Protection Shutter
- Sleek & Trendy Design
- Smooth & Silent Operation
- Easy To Install

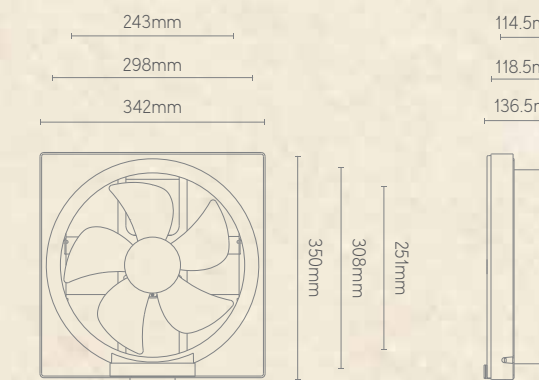



AIR-MAXX PLUS

Exhaust Fan



White-Grey

ITEM CODE	SWEEP	WATTAGE	SPEED	AIR DELIVERY
EFS 850406	150 mm	35W	1350 RPM	280 CMH
EFS 850408	200 mm	38W	1300 RPM	550 CMH
EFS 850410	250 mm	40W	1250 RPM	750 CMH



Some rooms need more ventilation than others. For such places, Goldmedal has the Air-Maxx Plus exhaust fan that functions at a speed of 1300 RPM. Available in a single White-Grey shade, this exhaust fan also comes with a safety guard for an added layer of protection.

PRODUCT HIGHLIGHTS

- Super Efficient Motor
- Detachable Front Grill
- Sleek & Trendy Design
- Easy To Install
- Dust Protection Shutter
- Smooth & Silent Operation

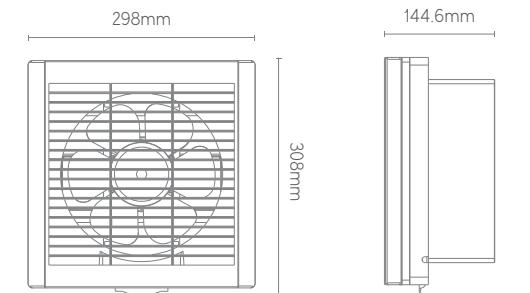



HAVOC

Exhaust Fan



True to its name, the Havoc will powerfully suck all the dirt and fumes out of your room with ease. It comes with a robust motor and specially designed metal blades to deliver a havoc-quality performance. It also features a sturdy bird guard that prevents entry of birds and a rubber gasket that ensures zero vibration operation.



Grey

ITEM CODE	SWEEP	WATTAGE	SPEED	AIR DELIVERY
EFS 850906	150 mm	40W	2350 RPM	350 CMH
EFS 850909	225 mm	35W	1350 RPM	550 CMH
EFS 850912	300 mm	45W	1350 RPM	1250 CMH



PRODUCT HIGHLIGHTS

- Powerful Motor
- Powder Coated Finish
- Sturdy Bird Guard
- Specially Designed Metal Blade
- Rubber Gasket

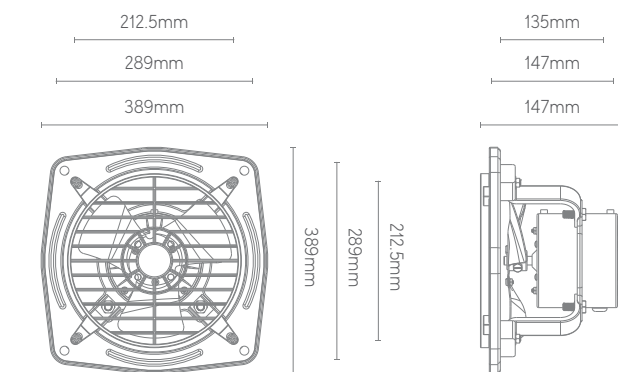

HAVOC PLUS

Exhaust Fan



Grey

ITEM CODE	SWEEP	WATTAGE	SPEED	AIR DELIVERY
EFS 851009	225 mm	70W	2500 RPM	1050 CMH
EFS 851012	300 mm	75W	2250 RPM	1600 CMH



This is a heavy duty upgrade to the Havoc exhaust fans. The Havoc Plus performs at higher wattage and functions at higher speeds. The powerful motor, powder coated finish and sturdy body guarantees supersonic performance while withstanding the test of time and atmospheric conditions. The blue outer frame gives the Havoc Plus a stylish edge over other exhaust fans.

PRODUCT HIGHLIGHTS

- Powerful Motor
- Powder Coated Finish
- Sturdy Bird Guard
- Specially Designed Metal Blade
- Rubber Gasket

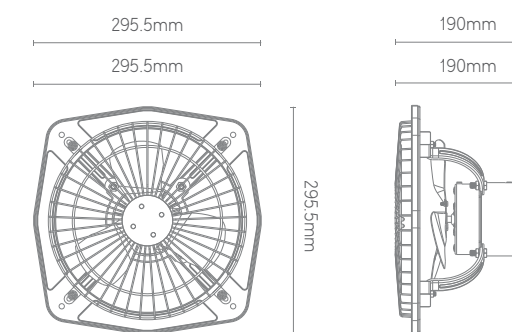



RAPIDO

Exhaust Fan



Count on the Rapido to rapidly clear the room of fumes and humid air. This heavy duty exhaust fan boasts a high speed, powerful motor that has high air thrust to clear the air. Its specially designed metal blade with powder coated finish prevents corrosion and thus extends its life span. With a classic design, the Rapido also features a sturdy bird guard that prevents the entry of birds into your premises.



Grey

ITEM CODE	SWEEP	WATTAGE	SPEED	AIR DELIVERY
EFS 851306	150 mm	50W	2050 RPM	600 CMH
EFS 851309	225 mm	46W	1380 RPM	550 CMH
EFS 851312	300 mm	52W	1380 RPM	1200 CMH



PRODUCT HIGHLIGHTS

- High Speed Powerful Motor
- High Air Thrust
- Sturdy Bird Guard
- Specially Designed Metal Blade
- Powder Coated Finish

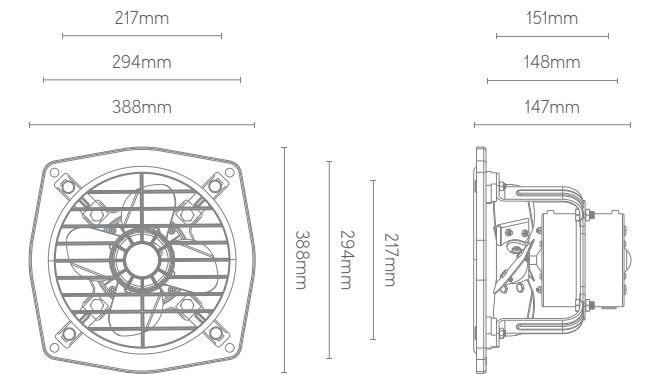

CEILING



Daisy (BLDC) Phantom (BLDC) Viola Hush-Air (BLDC) Gladiator Thor Flora Hero Prime



Insignia Hoopla Senora Eva Prime Enzo Air Crest Airavat DX Airavat Vector



Gati Deco Legacy 390 Geo Fox (BLDC) Lux Flow (BLDC) Gati 400 Vegah 400 Air GT Volt 400

LIFESTYLE

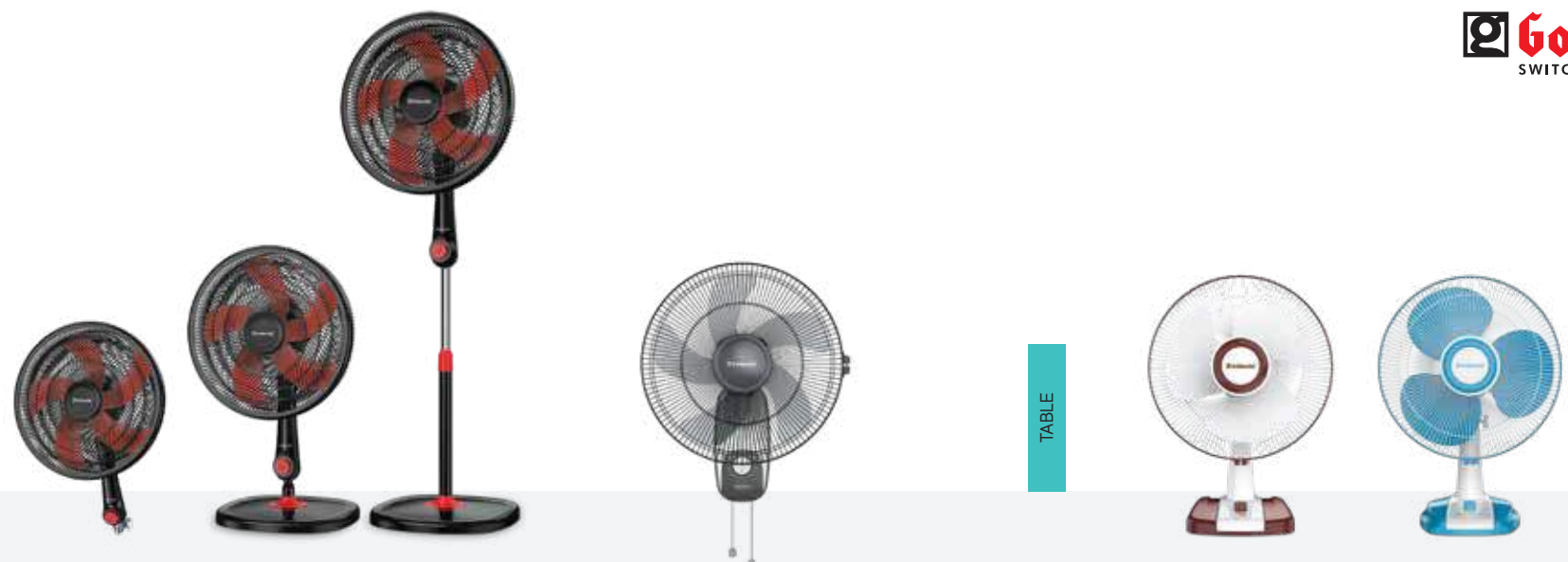

Tricool Adora Nora Erica

TABLE

WALL

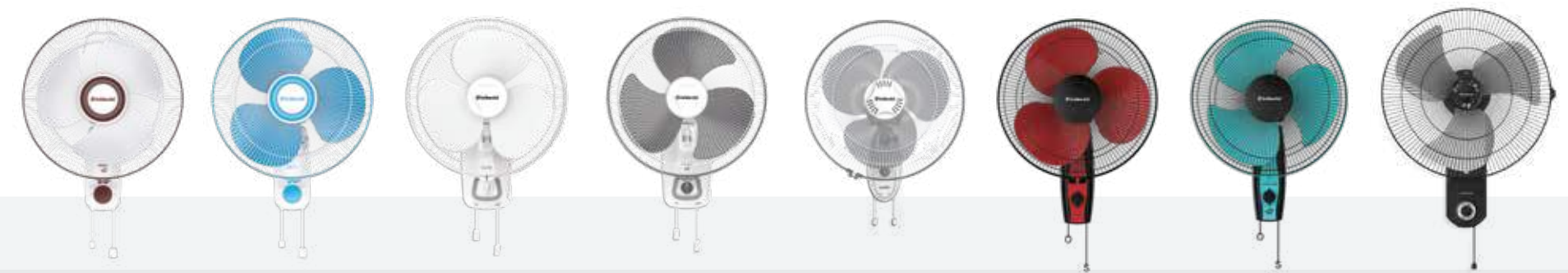

Nora Erica Olivia Olivia Pro Gloria Dyno Dyno Pro G-Express

PEDESTAL



Gloria Nora Erica Olivia Olivia Pro Dyno Dyno Pro

AXIAL



Frost Frost Prime Air Vent Nova Pro Nova Aero Aria Vento

PERSONAL

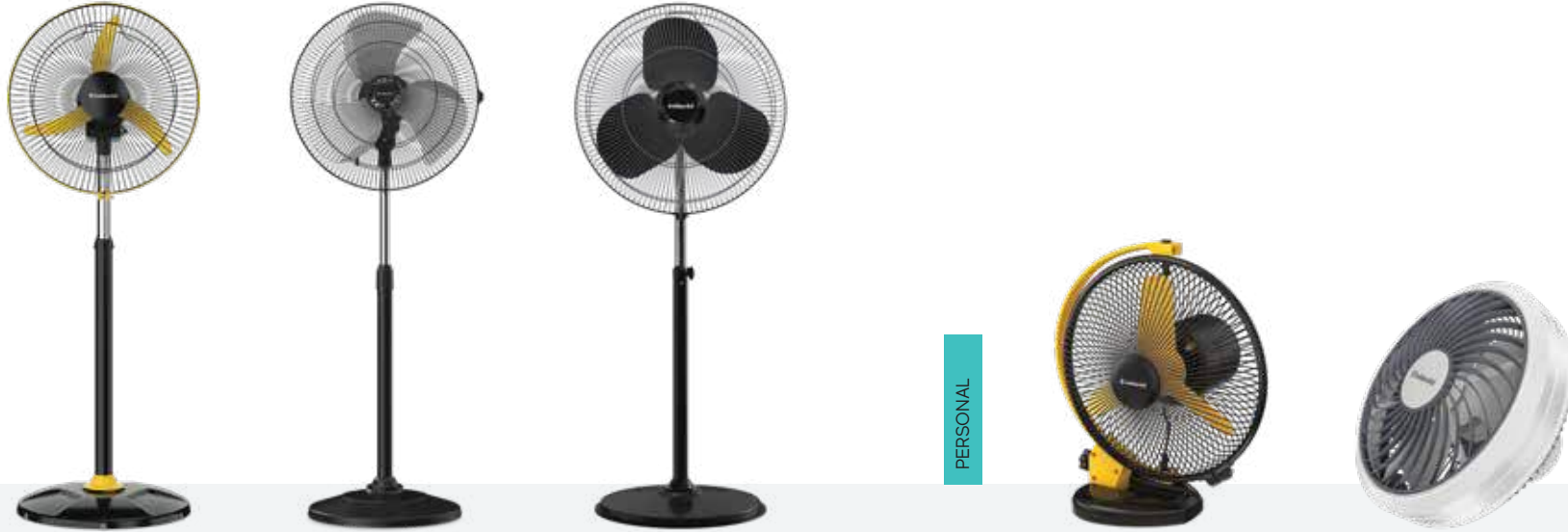

Falcon G-Xpress Farata - Torpedo/Turbo Storm Tristar astor

VENTILATION



Air-Maxx HS | Air-Maxx Air-Maxx Plus Havoc Havoc Plus Rapido

CEILING FANS

CATEGORY	MODEL CODE	MODEL NAME	SWEEP (MM)	POWER (WATT)	SPEED (RPM)	AIR DELIVERY (CMM)	WARRANTY (YEARS)	PKG
Super Decorative	CFZ 101448	Daisy BLDC	1200	40	330	220	2+1*	1
	CFZ 100148	Phantom BLDC	1200	40	300	220	2+1*	1
	CFZ 101748	Viola	1200	52	330	220	2	4
	CFZ 100750	Hush-Air BLDC	1250	40	280	230	2+1*	2
	CFZ 100948	Gladiator	1200	52	350	220	2	2
Decorative	CFZ 101124	Thor	600	65	850	105	2	4
	CFP 300348	Flora	1200	52	380	220	2	2
	CFP 301548	Hero Prime	1200	54	380	230	3	2
	CFP 300548	Insignia	1200	52	380	225	2	2
	CFP 301136	Hoopla	900	45	450	140	2	2
	CFP 301148	Hoopla	1200	50	380	225	2	2
	CFP 300948	Senora	1200	50	380	220	2	4
	CFP 301748	Eva Prime	1200	50	400	220	2	4
	CFP 301324	Enzo	600	65	850	105	2	4
	CFP 301336	Enzo	900	45	450	140	2	4
Classic Decorative	CFP 301348	Enzo	1200	50	380	220	2	4
	CFP 301848	Air Crest	1200	50	400	215	3	4
	CFS 501548	Airavat DX	1200	52	400	220	2	4
	CFS 501248	Airavat	1200	52	400	220	2	4
	CFS 500848	Vector	1200	50	400	210	2	4
Standard	CFS 500348	Gati Deco	1200	50	400	210	2	4
	CFS 501348	Legacy 390	1200	52	400	225	2	4
	CFS 500948	Geo Fox BLDC	1200	35	350	220	2+1*	4
	CFS 500448	Lux Flow BLDC	1200	32	350	220	2+1*	4
	CFE 700224	Gati 400	600	65	850	105	2	4

Note: * 1 year extended warranty only on registration of product.

CEILING FANS

CATEGORY	MODEL CODE	MODEL NAME	SWEEP (MM)	POWER (WATT)	SPEED (RPM)	AIR DELIVERY (CMM)	WARRANTY (YEARS)	PKG
Standard	CFE 700236	Gati 400	900	45	450	140	2	4
	CFE 700248	Gati 400	1200	50	400	210	2	4
	CFS 700148	Vegah 400	1200	50	400	210	2	4
	CFS 700448	Air GT	1200	50	400	210	2	4
	CFS 501648	Volt 400	1200	50	400	210	2	4

LIFESTYLE FANS

	LFP 800118	Tricool	450	80	1350	105	2	2
	WFP 200716	Adora	400	55	1200	90	2	2

TABLE/WALL & PEDESTAL FAN

Table Fan	TFS 153516	Nora	400	110	2100	100	2	3
	TFS 150616	Erica	400	55	1300	75	2	3
Wall Fan	WFS 253512	Nora	300	65	2300	70	2	3
	WFS 253516	Nora	400	110	2100	100	2	3
	WFS 250516	Erica	400	55	1300	75	2	3
	WFS 252516	Olivia	400	60	1325	70	2	3
	WFS 250316	Olivia Pro	400	125	2100	90	2	3
	WFS 250616	Gloria	400	55	1350	70	2	2
	WFS 250716	Dyno	400	55	1350	70	2	3
	WFS 250416	Dyno Pro	400	110	2100	90	2	3
	WFP 200168	G-Express	450	90	1350	100	2	2

TABLE/WALL & PEDESTAL FAN

CATEGORY	MODEL CODE	MODEL NAME	SWEEP (MM)	POWER (WATT)	SPEED (RPM)	AIR DELIVERY (CMM / CMH)	WARRANTY (YEARS)	PKG
Pedestal Fan	PFS 400616	Gloria	400	55	1350	70	2	2
	PFS 403516	Nora	400	110	2100	75	2	2
	PFS 400516	Erica	400	55	1300	75	2	2
	PFS 402516	Olivia	400	60	1325	70	2	2
	PFS 400316	Olivia Pro	400	125	2100	90	2	2
	PFS 400716	Dyno	400	55	1350	70	2	2
	PFS 400416	Dyno Pro	400	110	2100	90	2	2
	FFS 550316	Falcon	400	105	2100	125	2	2
	FFS 550618	G-Express	450	90	1350	100	2	2
	FFS 550720	Torpedo	500	140	1350	100	2	1
	FFS 550820	Turbo Storm	500	140	1350	100	2	1

CABIN & PERSONAL FAN

Cabin Fan	PCS 650212	Astor	300	75	2200	60	2	2
Personal Fan	PCS 650909	Tristar	225	45	2200	25	2	2

AXIAL & VENTILATION FANS

Axial Fan	AFP 700806	Frost	150	25	1900	236	2	12
	AFP 700704	Frost Prime	100	15	2200	75	2	16
	AFP 700706	Frost Prime	150	25	1900	236	2	12
	EFP 800108	Air Vent CM	200	65	2100	750	2	4
	AFP 701006	Nova Pro	150	18	2300	250	2	12

AXIAL & VENTILATION FANS

CATEGORY	MODEL CODE	MODEL NAME	SWEEP (MM)	POWER (WATT)	SPEED (RPM)	AIR DELIVERY (CMH)	WARRANTY (YEARS)	PKG
Axial Fan	AFS751104	Nova	100	18	2500	90	2	12
	AFS 751106	Nova	150	18	2300	250	2	8
	AFS 751108	Nova	200	24	2000	350	2	6
	AFS 750706	Areo	150	25	2250	240	2	6
	AFS 750906	Aria	150	25	2250	240	2	12
	AFS 751504	Vento	100	18	2500	90	2	8
	AFS 751506	Vento	150	22	1800	250	2	8
Ventilation Fan	AFS 751508	Vento	200	25	2000	350		
	EFS 850306	Air Maxx	150	35	1350	280	2	6
	EFS 850308	Air Maxx	200	38	1300	550	2	4
	EFS 850310	Air Maxx	250	40	1250	750	2	4
	EFS 850506	Air Maxx HS	150	40	2500	500	2	6
	EFS 850508	Air Maxx HS	200	65	2100	750	2	4
	EFS 850406	Air Maxx Plus	150	35	1350	280	2	4
	EFS 850408	Air Maxx Plus	200	38	1300	550	2	4
	EFS 850410	Air Maxx Plus	250	40	1250	750	2	4
Metal Fan	EFS 850906	Havoc (High Speed)	150	40	2350	350	2	6
	EFS 850909	Havoc	225	35	1350	550	2	4
	EFS 850912	Havoc	300	45	1350	1250	2	4
	EFS 851009	Havoc Plus	225	70	2500	1050	2	4
	EFS 851012	Havoc Plus	300	75	2250	1600	2	4
	EFS 851306	Rapido	150	50	2050	600	2	4
	EFS 851309	Rapido	225	46	1380	550	2	4
	EFS 851312	Rapido	300	52	1380	1200	2	4

SHOWROOMS

WEST

MUMBAI

E-1, Laxmi Industrial Estate,
New Link Road,
Andheri West, Mumbai - 400053
Tel: +91-22-40031075
Email: info@goldmedalindia.com

EAST

KOLKATA

Merlin Homeland Mall, Shop No. 123, 1st Floor,
18B, Ashutosh Mukherjee Road, Bhawanipore,
Kolkata - 700 020. Tel: +91- 8336956017
Email: kolkata@goldmedalindia.com

SILIGURI

International Market, 2nd Floor, Shop No. 3 & 4,
Sevoke Road, Near Panitanki More,
Beside Sky Star Building, Siliguri - 734001,
West Bengal. Tel: +91-8336084284
Email: ritesh.g@goldmedalindia.co.in

NORTH

JODHPUR

Plot No. E-99A, M. I. A.
Basni 2nd Phase, Jodhpur,
Rajasthan - 342005.
+91-9772210543
rajasthan@goldmedalindia.com

NOIDA

H-204, Sec-63
Noida, Uttar Pradesh - 201307
Tel: +91-120-4135901
Email: noida@goldmedalindia.com

JAIPUR

Goldmedal Electricals Private Limited
55, New Aatish Market, Mansarovar,
Jaipur - Rajasthan.
Tel: +91-291-3261955
Email: rajasthan@goldmedalindia.com

JALORE

Head Post Office Road,
Jalore - 343001, Rajasthan, India.
Tel: +91-2973222568
Email: rajasthan@goldmedalindia.com

SOUTH

HUBBALLI

Umachagi Complex, Koppikar Road, Hubballi,
Karnataka-580020
Tel: +91-0836-4258466
Email: bangalore@goldmedalindia.com

HYDERABAD

S-1, Ground Floor, Kalphakunja
Apartment 5-2-84/87, Jambagh,
Hyderabad-500095, Telangana
Tel: +91-40-24610722 / 9849172122
Email: hyderabad@goldmedalindia.com

VIJAYAWADA

2nd Floor, PVP Mall, Mahatma Gandhi Rd,
Labbipet, Vijayawada-520010, Andhra Pradesh
Tel: +91-9885676400
Email: vijayawada@goldmedalindia.com

VIJAYAWADA

D. No. 11-33-15, Tatakulavari Street,
Vijayawada-520 001, Andhra Pradesh
Tel: +91-866-6542000 / 8977574737
Email: vijayawada@goldmedalindia.com

KADAPA

21/96, Reddy Complex, Near 7 Road Circle,
Opp. Reddy Express, Kadapa- 516001,
Andhra Pradesh. Tel: +91-9885676400
Email: vijayawada@goldmedalindia.com

CALICUT

Shaherzad Shopping Complex, CH Flyover
Junction, Cherootty Road, Calicut - 673001,
Kerala. Tel: +91-9048743111
Email: calicut@goldmedalindia.com

COCHIN

3rd Floor, G K Arcade, Palarivattom
Bye Pass Junction,
Ernakulam - 682028, Kerala.
Tel: +91-9324936290
Email: calicut@goldmedalindia.com

COIMBATORE

D. No. 897, Avinashi Road,
Below Flyover,
Coimbatore-641018
+91-9324514945
chennai@goldmedalindia.com

BRANCHES

WEST

MUMBAI

119, Maskati Mahal, 3rd Floor, Room No.1- B,
Loharchawl, Marine Line, Mumbai - 400002,
Maharashtra, India. Tel: +91-22-39567558
Email: info@goldmedalindia.com

PALGHAR

Bldg. No.5, Shah Industrial Estate, Opp. Masjid,
Mourya Naka, Sativali, Vasai (E), Palghar-401208,
Maharashtra. Tel: +91-22-42023026
Email: mumbai@goldmedalindia.com

PUNE

741/1, Shop No.1 & 2, Gr. Floor, Kushal Sagar
Complex, Ganesh Rd, Budhwar Peth, Pune-411002,
Maharashtra, India. Tel: +91-9822098620
Email: pune@goldmedalindia.com

AHMEDABAD

Block No. 43, Behind Savex Technologies
Warehouse, Sanathal Bakrol Ring Road,
Village Badrabad, Ahmedabad, Gujarat- 382210
Tel: +91-9372200393
Email: ahmedabad@goldmedalindia.com

BHOPAL

Way No. 11-12, Multi Industries Warehouse,
Plot No. 13C, Industrial Area Govindpura,
Bhopal, Madhya Pradesh - 462023
Tel: +91-9589080144
Email: bhopal@goldmedalindia.com

RAIPUR

1st Floor, Plot No.15, Kedia Business Park,
Tatibandh, Raipur, Raipur - 492099,
Chhattisgarh, India. Tel: +91-7714910078
Email: raipur@goldmedalindia.com

EAST

KOLKATA

1/1B/4, Ram Krishna Naskar Lane Beliaghata,
Kolkata - 700010, West Bengal.
Tel: +91-8336907040
Email: kolkata@goldmedalindia.com

PATNA

Plot No.846, Mohalla East Ashu Chak,
P.o. Purvilakshmi Nagar, Krishna Niketan
School Road, Agamkuan, Patna-800030,
Bihar, India. Tel: +91-9798606400
Email: patna@goldmedalindia.com

RANCHI

R S Plot No. 2072, Near Dalaldali Chowk,
Simaliya, P. S, Ratu Ranchi-834005,
Jharkhand, India. Mobile- 9431170402
Email: ranchi@goldmedalindia.com

GUWAHATI

NH-37, Nr. Tirupati Parking, Opp. Audi Showroom,
Guwahati-781029, Assam, India. Tel: +91- 9718077070.
Email: guwahati@goldmedalindia.com

CUTTACK

Plot No.1047 & 1048, Opp. Axis Bank, Jagatpur,
Cuttack- 754021, Odisha (Orissa), India.
Tel: +91- 9437452303
Email: cuttack@goldmedalindia.com

JODHPUR

Plot no. E-99A, M. I. A. Basni 2nd Phase,
Jodhpur, Rajasthan-342005. Tel: +91-9772210543
Email: rajasthan@goldmedalindia.com

LUCKNOW

C1-5, Phase-2, Transport Nagar, Lucknow-226012,
Uttar Pradesh, India. Tel: +91-8780887400
Email: lucknow@goldmedalindia.com

NOIDA

H-204, Sec-63, Noida, Uttar Pradesh-201307
Tel: +91-120-4135901
Email: noida@goldmedalindia.com

DEHRADUN

A-39, Transport Nagar, Sewla Khurd, Dehradun-248001,
Uttarakhand, India. Tel: +91-135 - 2649522
Email: dehradun@goldmedalindia.com



MOHALI

855/C, Janta Industrial Estate, Sector - 82,
Mohali, Mohali-160055, Punjab, India.
Customer Care : 9711 09 09 09
Email: mohali@goldmedalindia.com

SOUTH

BENGALURU

Level 2/3/4, Regal Arcade No. 1-2, 5th Cross,
Mysore Road, Bengaluru, Karnataka - 560026
Tel: +91-80-41687799/41759977
Email: bangalore@goldmedalindia.com

VIJAYAWADA

20-127/2, By Pass Road, Gollapudi, Krishna
District, Vijayawada - 521225, Andhra Pradesh
Tel: +91-866-6542333/6542888
Email: vijayawada@goldmedalindia.com

HYDERABAD

Central Warehouse Corporation A2, P B No 34,
Behind Gandhi Bhavan, Nampally, Hyderabad
-500001, Telangana. Tel: +91-40-29706099
Email: hydteam@goldmedalindia.com

CHENNAI

92/6, Nattu Pillaiar Koil Street Sowcarpet,
Chennai - 600001, Tamil Nadu, India.
Tel: +91-44-49521008
Email: chennai@goldmedalindia.com

CALICUT

Door No.1/60, Baby Marine Export Compound,
Temple Road, West Hill Calicut, Kozhikode (Calicut),
Kozhikode-673005, Kerala, India.
Customer Care : 9711 09 09 09
Email: calicut@goldmedalindia.com

NOTES

NOTES



Regd. office:
Goldmedal Electricals Pvt. Ltd.
A/303, Kemp Plaza, Off Link Road,
MindSPACE, Chincholi Bunder, Malad (W),
Mumbai-400064, Maharashtra, India

Web: www.goldmedalindia.com
Email: info@goldmedalindia.com
Customer care no.: 91-9711 09 09 09

Goldmedal, Curve, Nixon, Air, Ringo,
Gifa & Cloud9 are registered trademarks
of Goldmedal Electricals Pvt. Ltd.
Copyright protected by Goldmedal. No part of this
pricelist & catalogue may be printed or duplicated
without consent of Goldmedal Electricals Pvt.
Ltd. Patent, Trademark & Designs protected.
Infringement is liable for prosecution. Imitation
of graphics is a punishable offence.
Brand identity, concept & design of
Goldmedal Electricals Pvt. Ltd.



SCAN this QR-code from your
smart phone to visit our website



Term & Conditions

Warranty applicable on products are as per
Goldmedal's warranty policy.
Continuous design and product development is a routine
practice at Goldmedal, so data in this catalogue
provided may change without prior information or
notice. Customers are advised to check current data
before purchasing any product.

