

VENTILATION FOR
MODERN SPACE
FANS BY GOLDMEDAL

TRIPLE TRIUMPH A HAT-TRICK IN DESIGN EXCELLENCE

THREE GLOBAL AWARDS.

One relentless pursuit of design excellence. From tactile innovation to silent performance to responsive lighting — Goldmedal is redefining how design lives and feels.

In 2025, the Loom Switch won the Red Dot Award for reimagining the modular switch, using a distinctive, tactile fabric interface. The Hush Flo BLDC Ceiling Fan received India's Best Design Project 2025 award, celebrating its sleek aesthetics and whisper-quiet performance. In early 2026, the ROOTS Lighting System earned the iF Design Award for its nature-inspired, modular design that responds dynamically to indoor air quality. Together, these accolades reflect Goldmedal's singular vision to elevate everyday living through thoughtful design.



reddot winner 2025



WINNER OF
INDIA'S
BEST
**DESIGN
PROJECT
2025**



winner 2026

FRESHNESS IN
EVERY CORNER



01

AXIAL FAN

06 - 15

FROST PRIME | FROST | AIRFY NEO | AIRFY | X9 | XO VENT
VENTURA NEO | VENTURA | NOVA PRO | NOVA | AERO
AIR VENT CM | TRIGO | VENTO

02

VENTILATION FAN

16 - 25

AIR MAXX BLDC | AIR MAXX | AIR MAXX HS | AIR MAXX ULTRA
TORQUE DBB | HAVOC | HAVOC PLUS | RAPIDO | BLAST AIR



Rich Black



Rich Black (With Light)



White Rose Wood



White

FROST PRIME | FROST
AXIAL EXHAUST FAN



PRODUCT HIGHLIGHTS

- Aerodynamic & Cutting-Edge Design • Ambient LED Light • Smooth & Silent Operation
- Perimeter Extraction System • Easily Removable Front Cover For Cleaning
- Quick-Fix Grip with Exclusive Mounting System
- Backdraft Shutters • Longer Durability • ABS Plastic Material

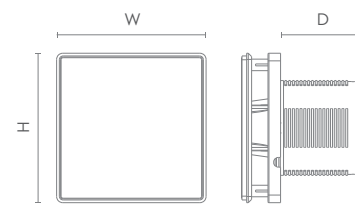

FROST PRIME

ITEM CODE	SWEEP	WATTAGE	SPEED	AIR DELIVERY	DIMENSION	CUT OUT
AFP700704	100 mm	15 W	2200 RPM	75 CMH	157x157x86	Ø 105
AFP700706	150 mm	25 W	1900 RPM	236 CMH	200x200x120	Ø 153

FROST

ITEM CODE	SWEEP	WATTAGE	SPEED	AIR DELIVERY	DIMENSION	CUT OUT
AFP700806	150 mm	25 W	1900 RPM	236 CMH	200x200x120	Ø 153

*All dimension (WxHxD) in mm



AIRFY NEO | AIRFY
AXIAL EXHAUST FAN



PRODUCT HIGHLIGHTS

- Aerodynamic & Cutting-Edge Design • Ambient LED Light • Smooth & Silent Operation
- Better Air Suction • Perimeter Extraction System • Easily Removable Front Cover For Cleaning
- Quick-Fix Grip with Exclusive Mounting System • Super Efficient Motor
- Safe And Reliable • Backdraft Shutters • Longer Durability

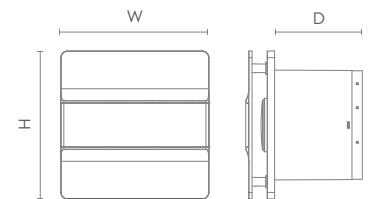

AIRFY NEO WITH LED LIGHT

ITEM CODE	SWEEP	WATTAGE	SPEED	AIR DELIVERY	DIMENSION	CUT OUT
AFP700506	150 mm	18 W	2200 RPM	250 CMH	200x200x120	Ø 155

AIRFY

ITEM CODE	SWEEP	WATTAGE	SPEED	AIR DELIVERY	DIMENSION	CUT OUT
AFP700206	150 mm	18 W	2200 RPM	250 CMH	200x200x120	Ø 155

*All dimension (WxHxD) in mm





Rose Wood



Black Steel



Black



White

X9
AXIAL EXHAUST FAN



PRODUCT HIGHLIGHTS

- Aerodynamic & Cutting-Edge Design • Super Efficient Motor
- Pilot LED Light • Mosquito Net • Smooth & Silent Operation • Better Air Suction
- Perimeter Extraction System • Easily Removable Front Cover For Cleaning • Backdraft Shutters
- Quick-Fix Grip with Exclusive Mounting System • Low Power Consumption

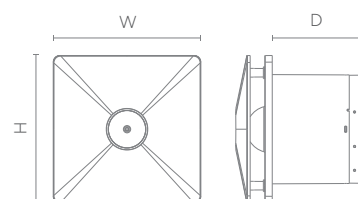

ITEM CODE	SWEEP	WATTAGE	SPEED	AIR DELIVERY	DIMENSION	CUT OUT
AFP701206	150 mm	18W	2200 RPM	250 CMH	200x200x120	Ø 155

*All dimension (WxHxD) in mm



Rose Wood



Black

XO VENT
AXIAL EXHAUST FAN

PRODUCT HIGHLIGHTS

- Aerodynamic & Cutting-Edge Design • Super Efficient Motor
- Smooth & Silent Operation • Better Air Suction • Perimeter Extraction System
- Easily Removable Front Cover For Cleaning • Backdraft Shutters
- Quick-Fix Grip with Exclusive Mounting System • Longer Durability

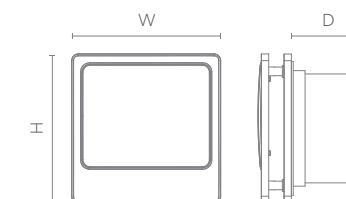

ITEM CODE	SWEEP	WATTAGE	SPEED	AIR DELIVERY	DIMENSION	CUT OUT
AFP700306	150 mm	18W	2200 RPM	250 CMH	200x200x100	Ø 155

*All dimension (WxHxD) in mm



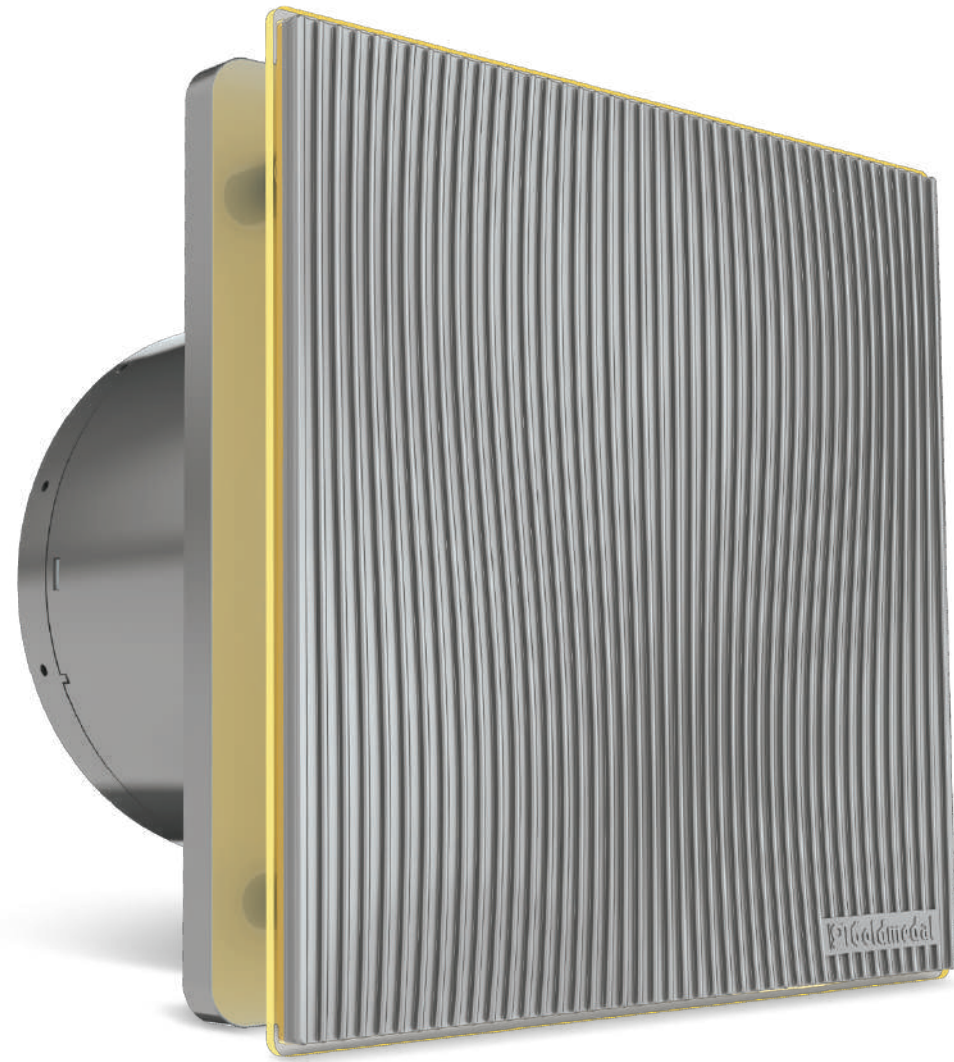

White

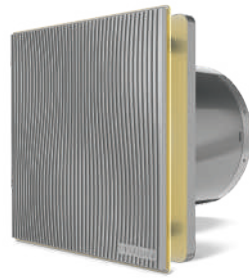

Dark Grey

VENTURA NEO | VENTURA
AXIAL EXHAUST FAN



PRODUCT HIGHLIGHTS

- Aerodynamic & Cutting-Edge Design • Ambient LED Light • Smooth & Silent Operation
- Better Air Suction • Perimeter Extraction System • Easily Removable Front Cover For Cleaning
- Quick-Fix Grip with Exclusive Mounting System • Super Efficient Motor
- Safe And Reliable • Backdraft Shutters • Longer Durability

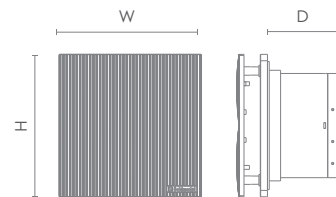

VENTURA NEO WITH LED

ITEM CODE	SWEEP	WATTAGE	SPEED	AIR DELIVERY	DIMENSION	CUT OUT
AFP700406	150 mm	18W	2200 RPM	250 CMH	206x206x120	Ø 155

VENTURA

ITEM CODE	SWEEP	WATTAGE	SPEED	AIR DELIVERY	DIMENSION	CUT OUT
AFP7001106	150 mm	18W	2200 RPM	250 CMH	200x200x100	Ø 155



*All dimension (WxHxD) in mm



White



Black



White (With Light)

NOVA PRO | NOVA
AXIAL EXHAUST FAN



PRODUCT HIGHLIGHTS

- Aerodynamic & Cutting-Edge Design • Ambient LED Light • Smooth & Silent Operation
- Better Air Suction • Easily Removable Front Cover For Cleaning
- Quick-Fix Grip with Exclusive Mounting System • Super Efficient Motor
- Safe And Reliable • Backdraft Shutters • Longer Durability

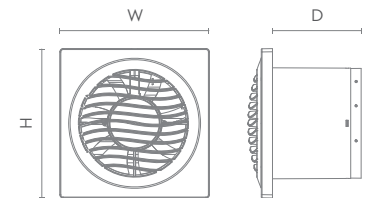

NOVA PRO WITH LED LIGHT

ITEM CODE	SWEEP	WATTAGE	SPEED	AIR DELIVERY	DIMENSION	CUT OUT
AFP701006	150 mm	18 W	2200 RPM	250 CMH	200x200x100	Ø 155

NOVA

ITEM CODE	SWEEP	WATTAGE	SPEED	AIR DELIVERY	DIMENSION	CUT OUT
AFS751104	100 mm	18 W	2600 RPM	90 CMH	150x150x87	Ø 103
AFS751106	150 mm	18 W	2200 RPM	250 CMH	200x200x100	Ø 155
AFS751108	200 mm	25 W	2000 RPM	350 CMH	250x250x115	Ø 185



*All dimension (WxHxD) in mm



White



White

AERO
AXIAL EXHAUST FAN



PRODUCT HIGHLIGHTS

- Aerodynamic & Cutting-Edge Design • Super Efficient Motor
- Pilot LED Light • Smooth & Silent Operation • Better Air Suction
- Perimeter Extraction System • Easily Removable Front Cover For Cleaning • Backdraft Shutters
- Quick-Fix Grip with Exclusive Mounting System • Low Power Consumption

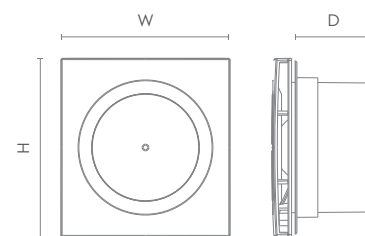

ITEM CODE	SWEEP	WATTAGE	SPEED	AIR DELIVERY	DIMENSION	CUT OUT
AFS750706	150 mm	25 W	2250 RPM	250 CMH	190x200x85	Ø 150

*All dimension (WxHxD) in mm

AIR VENT CM
AXIAL EXHAUST FAN



PRODUCT HIGHLIGHTS

- Unique & Sleek Design • Smooth & Silent Operation
- Roof / Ceiling Mounting • Easily Removable Front Cover For Cleaning
- Super Efficient Motor • Better Air Suction
- Quick-Fix Grip with Exclusive Mounting System

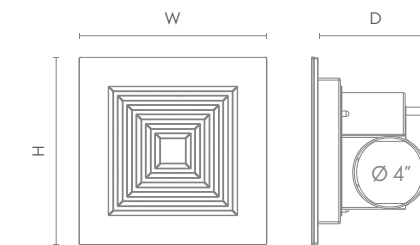

ITEM CODE	SWEEP	WATTAGE	SPEED	AIR DELIVERY	DIMENSION	CUT OUT
EFP800108	200 mm	28 W	1250 RPM	200 CMH	260x260x160	205x205

*All dimension (WxHxD) in mm



Black



White



Ivory



Black

TRIGO

AXIAL EXHAUST FAN

PRODUCT HIGHLIGHTS

- Aerodynamic & Cutting-Edge Design • Smooth & Silent Operation
- Easily Removable Front Cover For Cleaning • Super Efficient Motor • Better Air Suction
- Quick-Fix Grip with Exclusive Mounting System • Backdraft Shutters

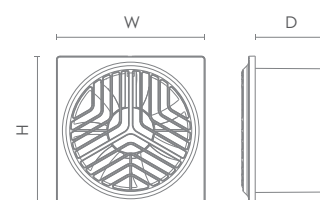

ITEM CODE	SWEEP	WATTAGE	SPEED	AIR DELIVERY	DIMENSION	CUT OUT
AFS750106	150 mm	18W	2200 RPM	250 CMH	180x180x85	Ø 155
AFS750108	200mm	25W	2000 RPM	350 CMH	250x250x100	Ø 185

*All dimension (WxHxD) in mm



VENTO

AXIAL EXHAUST FAN

PRODUCT HIGHLIGHTS

- Aerodynamic & Cutting-Edge Design • Smooth & Silent Operation
- Easily Removable Front Cover For Cleaning • Super Efficient Motor
- Better Air Suction • Quick-Fix Grip with Exclusive Mounting System

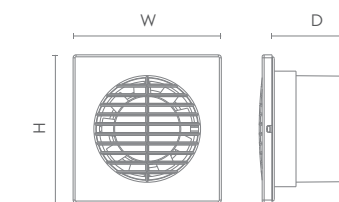

ITEM CODE	SWEEP	WATTAGE	SPEED	AIR DELIVERY	DIMENSION	CUT OUT
AFS751504	100 mm	18 W	2600 RPM	90 CMH	150x150x90	Ø 110
AFS751506	150 mm	22 W	2200 RPM	250 CMH	180x180x90	Ø 150
AFS751508	200 mm	25 W	2000 RPM	350 CMH	222x222x105	Ø 185

*All dimension (WxHxD) in mm





Black



White

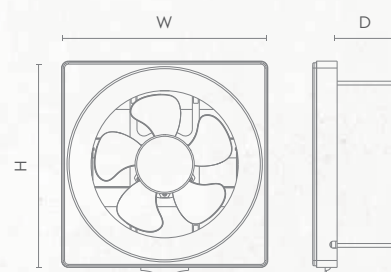

AIR MAXX BLDC
EXHAUST FAN

Introducing the Air Maxx BLDC exhaust fan, designed to deliver powerful ventilation with superior energy efficiency. Powered by a robust BLDC motor, it offers high-speed performance of up to 2000 RPM while consuming minimal power. Engineered for low-noise operation and strong air suction, it ensures effective airflow without disturbance. Its sleek design, insect-blocking back flaps, and easy installation make Air Maxx BLDC a smart and reliable ventilation solution for modern homes.

PRODUCT HIGHLIGHTS

- Energy-efficient BLDC Motor • High Air Suction
- Low Noise Operation • Back Flaps to Prevent Insects
- Sleek & Trendy Design • Easy To Install and Clean



ITEM CODE	SWEEP	WATTAGE	SPEED	AIR DELIVERY	DIMENSION	CUT OUT
EFS 850706	150 mm	10 W	2000 RPM	360 CMH	245x245x80	195x195
EFS 850708	200mm	15 W	1600 RPM	650 CMH	300x300x87	245x245

*All dimension (WxHxD) in mm





White



Black



Black



White

AIR-MAXX | AIR-MAXX HS EXHAUST FAN

PRODUCT HIGHLIGHTS

- Aerodynamic & Cutting-Edge Design • Super Efficient Motor • Sleek & Trendy Design
- Smooth & Silent Operation • Dust Protection Shutter • Easy To Install • Easy to Clean

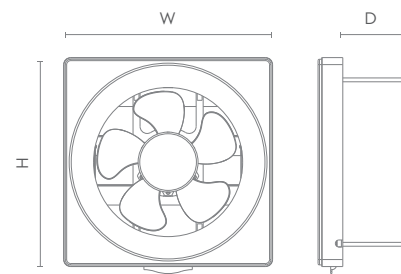

AIR-MAXX

ITEM CODE	SWEEP	WATTAGE	SPEED	AIR DELIVERY	DIMENSION	CUT OUT
EFS 850306	150 mm	35W	1350 RPM	280 CMH	245x245x80	195x195
EFS 850308	200 mm	38W	1300 RPM	550 CMH	300x300x87	245x245
EFS 850310	250 mm	40W	1250 RPM	750 CMH	345x345x90	297x297

AIR-MAXX HS

ITEM CODE	SWEEP	WATTAGE	SPEED	AIR DELIVERY	DIMENSION	CUT OUT
EFS 850506	150 mm	40W	2500 RPM	500 CMH	245x245x80	195x195
EFS 850508	200 mm	65W	2100 RPM	750 CMH	300x300x87	245x245

*All dimension (WxHxD) in mm



AIR-MAXX ULTRA EXHAUST FAN

PRODUCT HIGHLIGHTS

- Aerodynamic & Cutting-Edge Design • Super Efficient Motor
- Sleek & Trendy Design • Smooth & Silent Operation
- Dust Protection Shutter • Easy To Install • Easy to Clean

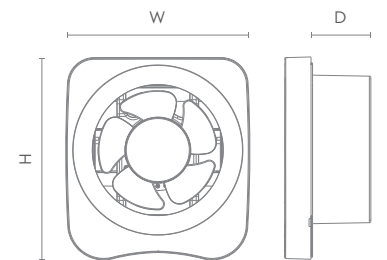

ITEM CODE	SWEEP	WATTAGE	SPEED	AIR DELIVERY	DIMENSION	CUT OUT
EFS850606	150 mm	29W	1400 RPM	280 CMH	240x263x80	195x195
EFS850608	200 mm	32W	1350 RPM	550 CMH	291x321x90	245x245
EFS850610	250 mm	34W	1300 RPM	790 CMH	345x380x90	297x297

*All dimension (WxHxD) in mm



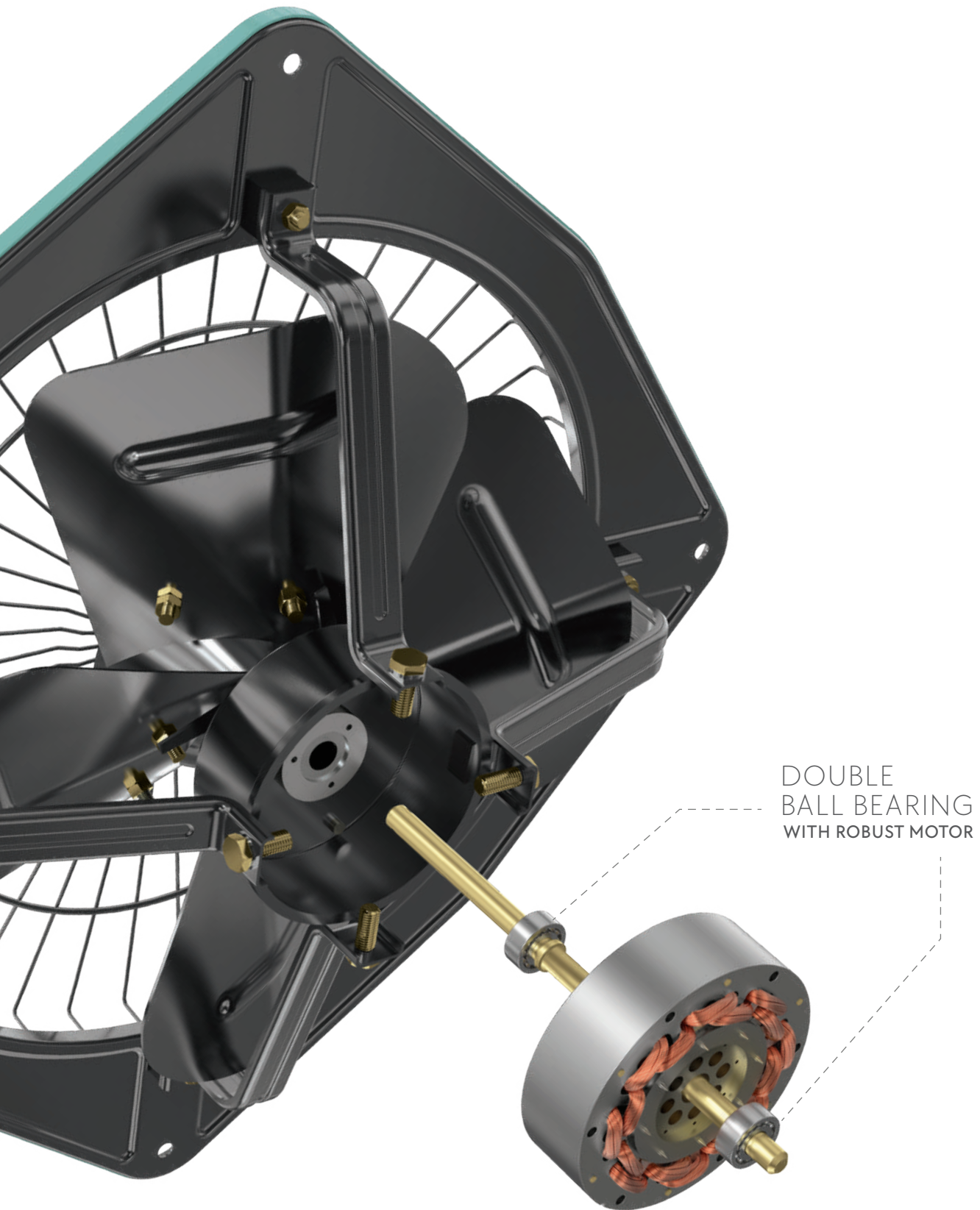

TORQUE DBB
EX VENT EXHAUST FAN

Experience cleaner air with the Torque DBB Exhaust Fan. Engineered with double ball bearings, it delivers enhanced durability, longer life, and consistently smooth performance. The powerful motor ensures efficient air circulation, while its quiet operation adds to everyday comfort. The integrated rubber gasket helps minimise vibrations for a more stable and noise-free experience. Designed for easy installation, it offers seamless and reliable performance.



PRODUCT HIGHLIGHTS

- Powerful Motor • Powder Coated Finish • Sturdy Bird Guard
- Specially Designed Metal Blade • Rubber Gasket

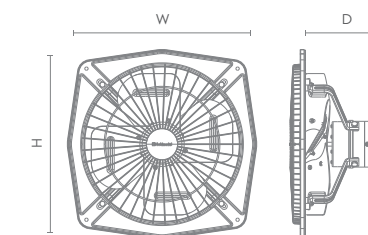

ITEM CODE	SWEEP	WATTAGE	SPEED	AIR DELIVERY	DIMENSION	CUT OUT
EFS850109	225 mm	50W	1380 RPM	900 CMH	295x295x169	Ø 270
EFS850112	300 mm	75W	1380 RPM	1710 CMH	394x394x185	Ø 360

*All dimension (WxHxD) in mm





Grey



Grey

HAVOC
EX VENT EXHAUST FAN

PRODUCT HIGHLIGHTS

- Powerful Motor • Powder Coated Finish • Sturdy Bird Guard
- Specially Designed Metal Blade • Rubber Gasket

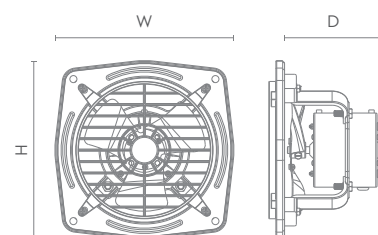

ITEM CODE	SWEEP	WATTAGE	SPEED	AIR DELIVERY	DIMENSION	CUT OUT
EFS850906	150 mm	40W	2350 RPM	350 CMH	213x213x126	Ø 190
EFS850909	225 mm	35W	1350 RPM	550 CMH	290x290x140	Ø 270
EFS850912	300 mm	45W	1350 RPM	1250 CMH	390x390x132	Ø 360

*All dimension (WxHxD) in mm



HAVOC PLUS
EX VENT EXHAUST FAN

PRODUCT HIGHLIGHTS

- Powerful Motor • Powder Coated Finish • Sturdy Bird Guard
- Rubber Gasket • Specially Designed Metal Blade

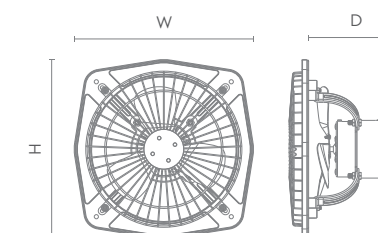

ITEM CODE	SWEEP	WATTAGE	SPEED	AIR DELIVERY	DIMENSION	CUT OUT
EFS851009	225 mm	70W	2500 RPM	1050 CMH	295x295x169	Ø 270
EFS851012	300 mm	75W	2250 RPM	1600 CMH	394x394x185	Ø 360

*All dimension (WxHxD) in mm





Grey

RAPIDO
EX VENT EXHAUST FAN

PRODUCT HIGHLIGHTS

- High Speed Powerful Motor • High Air Thrust
- Sturdy Bird Guard • Specially Designed Metal Blade
- Powder Coated Finish

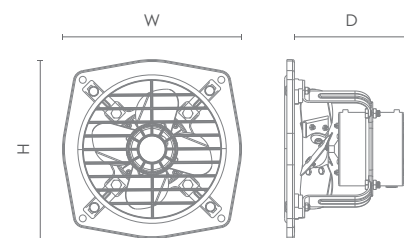

ITEM CODE	SWEEP	WATTAGE	SPEED	AIR DELIVERY	DIMENSION	CUT OUT
EFS851306	150 mm	50 W	2300 RPM	600 CMH	217x217x148	Ø 180
EFS851309	225 mm	46 W	1400 RPM	550 CMH	294x294x123	Ø 265
EFS851312	300 mm	52 W	1350 RPM	1200 CMH	389x389x132	Ø 350

*All dimension (WxHxD) in mm

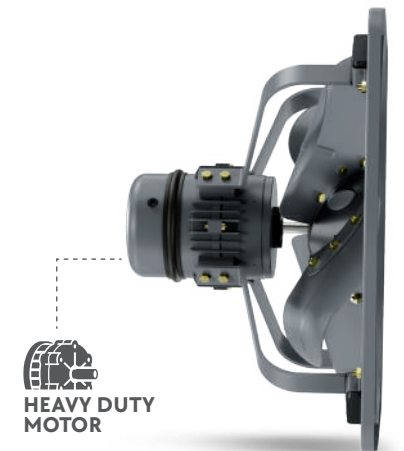

HEAVY DUTY MOTOR

Grey

BLAST AIR
HEAVY DUTY INDUSTRIAL EXHAUST FAN

PRODUCT HIGHLIGHTS

- Study Aluminium Body With 4 Metal Blade • High Air Thrust
- Earthing Provision For Human Safety • Powder Coated Metallic Finish
- Heavy Duty Motor With Double Ball Bearing

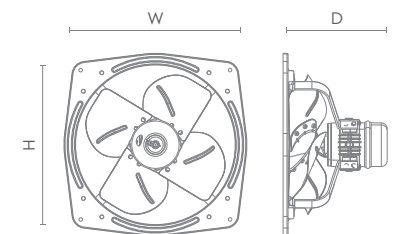

ITEM CODE	SWEEP	WATTAGE	SPEED	AIR DELIVERY	DIMENSION	CUT OUT
IHE80011814	450 mm	350W	1400 RPM	6120 m ³ /h	505x505x310	Ø 490

*All dimension (WxHxD) in mm



AXIAL FANS



Frost Prime - Black (With Light)



Frost - Black



Airfy Neo - White (With Light)



Airfy - White Rose Wood



Vento - Black



X9 - Black



X9 - White



X9 - Rose Wood



X9 - Black Steel

VENTILATION FANS



XO Vent - Black



XO Vent - Rose Wood



Ventura Neo - Dark Grey



Ventura - White



Air Maxx BLDC - White



Air Maxx BLDC - Black



Air Maxx - White



Air Maxx - Black



Nova Pro - White (Light)



Nova - Black



Nova - White



Aero - White



Air Maxx Ultra - White



Air Maxx Ultra - Black



Torque DBB - Grey



Havoc - Grey



Air Vent CM - White



Trigo - White



Trigo - Black



Vento - Ivory



Havoc Plus - Grey



Rapido - Grey



Blast Air - Grey

SHOWROOMS

WEST
AHMEDABAD

1106, Arista, 1st Floor, Opp Stellar, Sindhu Bhavan Road, Ahmedabad - 380058
 Tel: +91-8104965389
 Email: info@goldmedalindia.com

EAST
KOLKATA

Merlin Homeland Mall, Shop No. 123, 1st Floor, 18B, Ashutosh Mukherjee Road, Bhawanipore, Kolkata - 700 020. Tel: +91- 8336956017
 Email: showroom.kolkata@goldmedalindia.co.in

SILIGURI

International Market, 2nd Floor, Shop No. 3 & 4, Sevoke Road, Near Panitanki More, Beside Sky Star Building, Siliguri - 734001, West Bengal. Tel: +91-8336084284
 Email: ritesh.g@goldmedalindia.co.in

GUWAHATI

1st Floor Patwari Enclave, Kachari Basti, Near Dispur Collage, Ganeshguri, Guwahati - 781005.
 Tel: +91- 9718077070.
 Email: guwahati@goldmedalindia.com

RANCHI

B Square, Plot no.189, Beside Girdhar Plaza, Harmu Road, Ranchi-834001.
 Tel.: +91- 9431170402
 Email: ranchi@goldmedalindia.com

NORTH
JODHPUR

Plot No. E-99A, M. I. A. Basni 2nd Phase, Jodhpur, Rajasthan - 342005.
 +91-9772210543
 Email: rajasthan@goldmedalindia.com

NOIDA

H-204, Sec-63
 Noida, Uttar Pradesh - 201307
 Tel: +91-120-4135901
 Email: noida@goldmedalindia.com

JAIPUR

Goldmedal Electricals Private Limited 55, New Aatish Market, Mansarovar, Jaipur - Rajasthan.
 Tel: +91-291-3261955
 Email: rajasthan@goldmedalindia.com

JALORE

Head Post Office Road, Jalore - 343001, Rajasthan, India.
 Tel: +91-2973222568
 Email: rajasthan@goldmedalindia.com

SOUTH
HUBBALLI

Umachagi Complex, Koppikar Road, Hubballi, Karnataka-580020.
 Tel: +91-0836-4258466
 Email: bangalore@goldmedalindia.com

BENGALURU

No. 6/2 & 6/3, Mysore Road, Near Satellite Bus Station, Bengaluru, Karnataka -560026.
 Tel: +91-80-41687799/41759977
 Email: bangalore@goldmedalindia.com

HYDERABAD

4-1-690, Kothari Landmark, Old Vikranti Theatre, Mozamjahi Market, Hyderabad-500095,
 Telangana. Tel: +91-040-26706099
 Email: hyderabad@goldmedalindia.com

VIJAYAWADA

2nd Floor, PVP Mall, Mahatma Gandhi Rd, Labbipet, Vijayawada-520010, Andhra Pradesh
 Tel: +91-9885676400
 Email: vijayawada@goldmedalindia.com

VIJAYAWADA

D. NO. 11-33-15, Tatakulavari Street, Vijayawada-520 001, Andhra Pradesh
 Tel: +91-866-6542000 / 8977574737
 Email: vijayawada@goldmedalindia.com

KADAPA

21/96, Reddy Complex, Near 7 Road Circle, Opp. Reddy Express, Kadapa- 516001, Andhra Pradesh., Tel: +91-9885676400
 Email: vijayawada@goldmedalindia.com

CALICUT

Shaherzad Shopping Complex, CH Flyover Junction, Cherrooty Road, Calicut - 673001, Kerala.
 Tel: +91-9048743111
 Email: calicut@goldmedalindia.com

COCHIN

3rd Floor, G K Arcade, Palarivattom Bye Pass Junction, Ernakulam - 682028, Kerala., Tel: +91- 9497733334
 Email: calicut@goldmedalindia.com

COIMBATORE

D. No. 897, Avinashi Road, Below Flyover, Coimbatore - 641018.
 Tel: +91-9324514945
 Email: chennai@goldmedalindia.com

BRANCHES

WEST
MUMBAI

119, Maskati Mahal, 3rd Floor, Room No.1- B, Loharchawl, Marine Line, Mumbai - 400002, Maharashtra, India.
 Tel: +91-22-39567558/511
 Mob.: 9320687515
 Email: marinelines@goldmedalindia.com

REST OF MAHARASHTRA

Shakti Complex Building A, Unit No. 1/2/3/4/5, Survey No.20, Hissa No.167, Vadunavghar Reti Bundar, Kaman Bhiwandi Road, Bhiwandi, 421302, Bhiwandi, Maharashtra, India.
 Tel: +91- 9152013168
 Email: maharashtra@goldmedalindia.com

PUNE

CTS No 206-207, Ground Floor, Shop No.1, Shree Yash CHSL, Next to Yash Medical, Rasta Peth, Pune - 411011.
 Tel: +91-9822098620
 Email: pune@goldmedalindia.com

AHMEDABAD

Block No. 43, Behind Savex Technologies Warehouse, Sanathal Bakrol Ring Road, Near Essar (Near Nayana) Petrol Pump, Village Badrabad, Ahmedabad, Gujarat- 382210
 Tel: +91-9372200393
 Email: ahmedabad@goldmedalindia.com

BHOPAL

Way No. 11-12, Multi Industries Warehouse, Plot No. 13C, Industrial Area Govindpura, Bhopal, Madhya Pradesh - 462023
 Tel: +91-9589080144
 Email: bhopal@goldmedalindia.com

RAIPUR

1st Floor, Plot No.15, Kedia Business Park, Tatibandh, Raipur - 492099, Chhattisgarh, India.
 Tel: +91-7714910078
 Email: raipur@goldmedalindia.com

EAST
KOLKATA

KB 22, Bhakta Tower, 8th Floor, Salt Lake, Sector 3, Kolkata - 700098.
 Tel: +91-8336907040
 Email: kolkata@goldmedalindia.com

PATNA

Khata No.144 To 149, Thana No. 20, Khesara No.30 To 31, mahadev Asthan, Tent City, Near Bypass Police Thana, Agamkuan, Patna-800009, Bihar, India.
 Tel: +91-9798606400
 Email: patna@goldmedalindia.com

RANCHI

R S Plot No.2072, Near Dalaldali Chowk, Simaliya, P. S, Ratu, Ranchi - 834005, Jharkhand, India.
 Tel.: +91- 9431170402
 Email: ranchi@goldmedalindia.com

GUWAHATI

Ist Floor Patwari Enclave, Kachari Basti, Near Dispur Collage, Ganeshguri, Guwahati - 781005.
 Tel: +91- 9718077070.
 Email: guwahati@goldmedalindia.com

CUTTACK

Plot No.1047 & 1048, Opp. Axis Bank, Jagatpur, Cuttack- 754021, Odisha (Orissa), India. Tel: +91- 9437452303
 Email: cuttack@goldmedalindia.com

NORTH
JODHPUR

Plot no. E-99A, M. I. A. Basni 2nd Phase, Jodhpur, Rajasthan - 342005.
 Tel: +91-9772210543
 Email: rajasthan@goldmedalindia.com

LUCKNOW

C1-5, Phase 2, Transport Nagar, Lucknow - 226012, U.P. India.
 Tel: +91-0522-3513741 & 8655997461
 Email: goldmedallucknow@goldmedalindia.co.in

NOIDA

H-204, Sec-63, Noida, Uttar Pradesh - 201307
 Tel: +91-120-4135901
 Email: noida@goldmedalindia.com

SOUTH
MOHALI

855/C, Janta Industrial Estate, Sector - 82, Mohali-160055, Punjab, India.
 Tel: +91-9814141991
 Email: mohali@goldmedalindia.com

BENGALURU

No. 6/2 & 6/3, Mysore Road, Near Satellite Bus Station, Bengaluru, Karnataka -560026.
 Tel: +91-80-41687799/41759977
 Email: bangalore@goldmedalindia.com

VIJAYAWADA

20-127/2, By Pass Road, Gollapudi, Krishna District, Vijayawada - 521225, Andhra Pradesh
 Tel: +91-866-6542333/6542888
 Email: vijayawada@goldmedalindia.com

HYDERABAD

4-1-690, Kothari Landmark, Old Vikranti Theatre, Mozamjahi Market, Hyderabad-500095, Telangana.
 Tel: +91-040-26706099
 Email: hyderabad@goldmedalindia.com

CHENNAI

92/6, Nattu Pillaiar Koil Street Sowcarpet, Chennai - 600001, Tamil Nadu, India.
 Tel: +91-44-49521008
 Email: chennai@goldmedalindia.com

CALICUT

554-F & 554-G, Empirebuilding, Thenhippalam, Malappuram - 673636, Kerala, Tel: +91- 9497733334
 Email: calicut@goldmedalindia.com



Regd. office :

GOLDMEDAL ELECTRICALS PVT. LTD.

A/303, Kemp Plaza, Off Link Road, Mindspace, Chincholi
Bunder, Malad (W), Mumbai-400064, Maharashtra, India.

Web: www.goldmedalindia.com

Email: info@goldmedalindia.com

Copyright protected by Goldmedal.

No part of this pricelist & catalogue may be printed or duplicated
without consent of Goldmedal Electricals Pvt. Ltd. Patent,
Trademark & Designs protected. Infringement is liable for
prosecution. Imitation of graphics is a punishable offence. Brand
identity, concept & design of Goldmedal Electricals Pvt. Ltd.

CUSTOMER CARE NO.

9711 09 09 09

Chat with us on WhatsApp for any query or complaint

Term & Conditions

Warranty applicable on products are as per Goldmedal's warranty
policy. Continuous design and product development is a routine
practice at Goldmedal, so data in this catalogue provided may change
without prior information or notice, Customers are advised to check
current data before purchasing any product.



SCAN FOR THE
AMAZING





CUSTOMER CARE NO.
9711 09 09 09

Chat with us on WhatsApp for any query or complaint



1st EDITION
CAAF404261